

BALCONY views magazine

Innovative design solutions for contemporary building



by



Welcome to Balcony Views Magazine



Effi Wolff
Editor

Balcony Views Magazine is an exciting and effective way of communicating ideas, innovations, practical information and design concepts to architects, contractors, developers and self-builders.

Welcome to issue V of Balcony Views Magazine. The magazine showcases Balconette's products by focusing on real life projects where they've been used.

As a leading manufacturer and supplier in the fields of Glass Balconies, Curved Glazing and Decking we want to inspire designers, developers and home builders with our wide range of solutions.

The magazine is full of interesting projects both small and large scale that cover many different buildings, renovations and developments. In this issue we have also incorporated and included more in-depth technical information including some brand new products.

Whether you are an architect, in the trade, building your own home or simply like beautiful products, we hope our magazine inspires you and gives you some new ideas.

Enjoy the read . . .



Published by	Balconette
Editor	Effi Wolff
Design	Heather Dewhurst, Design to Print UK
Copywriter	Kathy Wilkinson
Production	Claire Wilkinson

The content of this magazine is copyright of Balconette. All rights reserved. Any redistribution or reproduction of part or all of the contents in any form is prohibited other than the following:

1. You may print extracts for your personal and non-commercial use only.
2. You may copy the content to individual third parties for their personal use but only if you acknowledge the magazine as the source of the material.

You may not, except with our express written permission, distribute or commercially exploit the content.

Photos: Front cover, p2, p22, p23 & back cover by Trevor Middleton



SUBSCRIBE

To subscribe to your **FREE** copy of *Balcony Views Magazine* or for information on all our products and services please visit: www.balconette.co.uk or call 01342 410411

Balconette is a trading name of Balcony Systems Solutions Ltd.



Contents

4 Self-build

↓
17 In this section we showcase how our products can enhance your home and what we can offer self-builders, home improvers and small developers.

18 Developers

↓
29 Showing off some of our larger projects in this section, we show our products installed and present ideas and solutions for house builders, contractors and larger scale developers.



30 Refurbishment

↓
34 See how our flexible range of products can transform your property without breaking the budget.

35 Technical

↓
50 Technical information about our Juliet Systems, Glass Balustrade Systems, Privacy Screens and Curved Door Systems.

51 BalcoNano®

↓
56 In this section we talk about our BalcoNano® advanced glass coating creating self-cleaning glass, how it works and what it can do for you.

57 Decking

↓
64 A new generation of Composite Decking, the future is here with a completely wood-free decking solution.

65 About Balconette

↓
67 In this section you can read about us and how we can work together as partners.



What Balconette can offer you for your Self-Build or Extension Project



Whether you are building a new home from scratch or adding an extension to enlarge your living space, Balconette can offer a range of solutions that enable you to include

that extra 'something' and a touch of 'wow factor' without overstretching your budget or creating obstacles towards completion.

Combining experience, expertise and technical innovations, our products are as visually appealing as they are practical in terms of installation, maintenance, quality of product and, of course, affordability.

Every project is unique and whether applied to a loft conversion, internal or external renovations, extensions, patios, decking or balconies, we can provide a flexible

range of possibilities to suit your specific requirements or, indeed, your imagination.

Whatever the scope of your project, we can also provide you with full back-up, such as help with the design and technical specifications, structural calculations and even the choice of the finishes and colours.

Alongside the quality, strength and durability of our Juliet balconies, balustrades, patio doors and decking, there is also timeliness of delivery and straightforwardness of installation, bolstered by full technical support and a nationwide network of installers should you need the help.

In other words, we work with you to ensure a smooth process that takes you from your initial idea right on through design, timely delivery, fitting and installation to the finished product.

And that's not all. Protective finishes to the glass and handrails mean they require virtually no maintenance

and minimal cleaning to keep them looking 'as new' for many years, while the glass in our windows and doors incorporates the latest technology to maintain high thermal efficiency.

The aesthetic appeal provided by Balconette's products is self-evident as you will see from the completed projects and customer testimonials featured in the following pages.

After you have taken a look, please feel free to ask any questions you may have and we will be pleased to answer them. You can take a tour of our website, email us, give us a call or even arrange to visit our showroom and factory to see our products first-hand.

5 Balconette's products were the 'right answer' for rural home

How curved patio doors and glass balustrade transformed a Buckinghamshire property.

6 Curved sliding doors are the 'heart and soul' of our project

Balconette's curved sliding doors add impact to Victorian Epping Forest home.

7 Balconette's curved patio door makes bold statement

One of Balconette's largest curved patio doors installed in the UK amply demonstrates the spectacular appeal of the product.

8 Balconette's glass garden balustrade produces 'an impressive result'

42 metres of the BAL 1 System with a Royal Chrome handrail installed at Somerset property.

9 14 metre outdoor balustrade with no posts

Perfect finish for hand-built garden terrace with Balconette's postless balustrading.

10 Balconette's balustrade is the clear solution to child safety

Glass balustrade separates play area from patio maintaining view of the garden and child safety.

11 Balconette adds 'wow factor' to Scandia-Hus Show Home

External balcony and extra-wide Juliet balcony blend in with Scandia-Hus style.

12 Exclusive homes showcase new Frameless Juliet balconies from Balconette

New Frameless Juliet balconies designed and built to exacting high standards in Harberton Mead.

13 Nothing obscures the view with a Frameless Juliet

Frameless glass Juliet balconies combine maximum light with minimum maintenance.

14 Balconette's products fully exploit Isle of Man views

Fantastic views through curved sliding patio doors and clear glass balustrading.

16 Balconette's breakthrough Infinity Screen announced

New glass balustrade product demonstrates a breakthrough solution for taller glass.

Balconette's products were the 'right answer' for rural home

Downsizing to a smaller home turned into a much bigger job than a retired Buckinghamshire couple could ever have envisaged as it became apparent that the property needed more than just a new roof.

When renovation plans for their detached property near High Wycombe ran into problems from the outset, they decided to rebuild it and include a stunning curved patio door and glass balustrade, both supplied and installed by Balconette.

"Both products have added the 'wow factor' and have given us so much the right answer," they say. "We were pleased that we could have virtually any curved door radius we wanted, which gave us the opportunity to make the sitting room bigger. So we just went for it. And we're so glad we did!"

Rebuilding the rural house, originally built in the early 1930s, took nearly two years. "Everything was wrong with it. The roof was only supported on three walls and there were hardly any foundations, so we ended up pulling it down and starting again."

Having decided against their architect's plans for a bay window on the rear elevation, the owners discovered Balconette while searching the internet for a 'totally different' door product.

They continue: "The curved sliding door enlarges the sitting room and lets

in lots of light. It's just what we wanted and we're delighted. We love to spend afternoons there just enjoying the panoramic views over the Hambleden Valley."

A 19 metre-long glass balustrade, also supplied and installed by Balconette, encloses the garden terrace and preserves the extensive countryside views from the curved door. It replaces

an 'ugly' brick wall with cast iron railing inserts that they considered 'just had to come out'.

"Friends say looking through the glass balustrade is like being on an ocean liner. Like the door, it's a real feature of the house," they add. "The whole installation process went smoothly and we would recommend Balconette."



Curved sliding doors are the 'heart and soul' of our project

Adding a curved sliding patio door to their Victorian home in Epping Forest has added impact, opened up views to the garden and created a highly-valued new living space for Nick Bowman and his partner Anne.

Fed up with a lack of natural light in their kitchen and a conservatory that also suffered from temperature extremes, the couple decided to demolish the conservatory and back wall to build an extension incorporating a 7.19 metre-wide curved sliding door supplied and installed by Balconette.

They engaged an architect to draw up plans from their design for a room with a curved rear glass wall to give a better view of their garden and

that would have 'more visual impact internally and externally'.

"The idea of a curve then informed the rest of the design," explains Nick, "so there is a curved ceiling detail that gives the appearance of a complete circle from the curved glass doors round through the ceiling, curved kitchen units and dining table."

Completing the theme is a curved tiled roof, linking the new extension with the existing structure and striking a

balance between the 'distinctive' door and its integration with the house.

During the quotation process, Nick found Balconette's website cost calculator was 'really important' in giving them a good start. "We had no idea of cost when we first started, so that opened up communication with them. We also visited the company's stand at Grand Designs Live – seeing and feeling the product was very important to us so that we could gauge the quality."

Having liked what they saw and impressed by the team's helpfulness and technical knowledge, the couple decided on Balconette. Nick continues: "Curved glass is significantly more expensive than a standard product...but the effect more than justifies that. Costings from other suppliers were higher (in one case by three times), so Balconette is clearly competitive on pricing.

"The units feel well-made and very solid, and after six months in situ we have no reason to doubt our

judgement. The service we received was always friendly, helpful and down-to-earth. The reflective coatings on the glass were an excellent recommendation – they also create some interesting reflections of a night-time, which is quite a talking point!"

Specific challenges relating to the supporting structure beneath a heavy tiled roof were overcome by using a structural engineer who devised a 'very neat and elegant solution' that does not obstruct the glazing.

Delighted with the result, the couple say the curved sliding doors are the 'heart and soul' of their project – once those were decided upon, everything could and did follow that.

"Now they are the first thing that visitors comment on – everyone loves them, and also the view of the garden. We sit in the curve for breakfast and dinner and find it a very relaxing space to talk about life, the universe and everything," adds Nick.



Balconette's curved patio door makes impressive statement

At nearly 10 metres wide, David and Lynn Walton's curved patio door with four fixed and four sliding panels makes a truly impressive statement at their Nottinghamshire home. It is also one of Balconette's largest curved patio doors installed in the UK and amply demonstrates the spectacular appeal of the product.



"It certainly achieves what we wanted; that is to make the most of views to the garden and we have brought the garden into our home," said David. "The door is a focal point in the living room where it forms an entire wall at one end. It's so striking and everyone likes it!"

"Now we have fitted the decking the curved patio door really comes into its own. It is never too hot or too sunny and the pleasure of the panoramic view of the garden cannot be over emphasised."

The door, finished with a RAL 7038 Agate Grey powder coating, was installed as part of extensive renovations to the 300-year-old property, which now comprises three former farmworkers' cottages in one.

Measuring 9.81m by 2m, the door forms a circular glass 'wall' flooding the living room extension with light. Directly above is a bedroom topped with an Oast House-effect pointed roof with glass apex that casts light into the room below.

The circular shape was originally designed with oak uprights, but the plans changed once the couple saw Balconette's curved patio door at the Grand Designs show and that sealed the deal for them.

"The price was right - and quite competitive - for what is a totally bespoke job," added David. "The door is so dramatic and there really is nothing quite like it on the UK market."

David and Lynn are now planning to fulfil their dream of a complete new self-build project and have put their four-bedroom home on the market at £675,000.

Balconette's glass garden balustrade produces 'an impressive result'

Replacing a wooden spindle balustrade with smart new low-maintenance glass balustrading supplied by Balconette has totally transformed the outdoor space at this Somerset property.

Renovation of the timber decking and installation of 42 metres of the Balcony BAL 1 System with a Royal Chrome handrail marked the final phase of several years of external refurbishment works at the Clark's home.

"Our decking is an important feature setting off both the house and garden, so the balustrade needed to be right. Balconette provided a quality product within budget which met our objectives and the overall effect is outstanding."

The project involved the renovation of a large expanse of seven year-old decking, wooden balustrade and some protective fencing all initially stained in cedar which had weathered to a chocolate brown colour.

The decking stain had to be removed by hand over a five-month period. The fence was removed and replaced in part by a wall, leaving the need to replace the wooden balustrade.

"Having given considerable thought to this we contacted and obtained quotes from several suppliers before our internet search identified Balconette. Their response to our initial phone call was positive; our questions answered appropriately and they

suggested that we contact Andy Harper of Somerset Bespoke."

Andy made two site visits indicating remedial work necessary before installation could be done and submitted a detailed plan to Balconette.

"We visited Balconette's Lingfield offices to see the product and get an idea of how it would look and have a valuable discussion with Graham Baxter, which allowed Andy to produce the final drawings."

"Throughout Balconette and Andy Harper were courteous and helpful. It was not an easy project as it involved a lot of work that we had to do ourselves, as well as Andy's contribution, which was itself quite substantive. But it all came together very well to produce an impressive result!"

Specifying Balconette's BalcoNano® factory-applied self-clean glass coating for the glass panels has made a difference. "The balustrade has dew on it most mornings which clears leaving the glass sparkling. The coating reduces the need to clean the glass, leaving us to simply sit back and enjoy it."



14 metre BAL 2 outdoor balustrade with no posts

Choosing glass balustrading from Balconette enabled a North Devon homeowner to provide the perfect finishing touch for his hand-built garden terrace.

Having found Balconette's products via an internet search, Ray, a semi-retired self-employed motor mechanic, and his wife Angelika decided that the system's clean lines and ability to retain countryside views were just what they were looking for.

"Best of all," he said, "was the fact I could have 14 metres of clear glass balustrading without a

single post! This keeps our totally transparent view from the garden across the valley and beyond. Our neighbours are extremely impressed, as indeed are we."

Ray built the original angular timber deck and balustrade when the couple moved into the 1970s bungalow in Bideford nearly fifteen years ago. Refurbishment



was needed when the old wooden balustrade started to rot, so he explored some options.

"I ruled out a glass and pillar system as this would have obscured the view," he continued. "Of the three quotes I obtained, although Balconette's was a bit more expensive I liked the appearance of the system and I wanted something that looked right."

With help from Balconette's Bill Boulter who assisted Ray with technical plans and advice, the new deck and balustrade quickly took shape. Ray found installing the system straightforward and 'the instructions were easy to follow'.

"Bill was very helpful in drawing up the plans. The lack of posts was a major reason for choosing the system, which sets it apart from other types of balustrading," he added. "The final three panes of glass only took half an hour to install and I'm delighted with the end result. We wanted a nice, clean-looking finish and this was exactly what we were looking for. All that's left is to treat the new patio to some new furniture!"

Balconette's BAL 1 balustrade is the clear solution to child safety

This garden balustrade, supplied and installed by Balconette, met the homeowner's critical requirements for child safety while also retaining clear views of the garden from the patio.

Built for a private client by building and civil engineering contractors R J Leighfield & Sons Ltd, the detached property near Swindon boasts an extensive garden with a trampoline – the perfect play area for young children.

Overcoming the challenges of sloping ground, a steep drop and the need for curves, the 28 metres of Balconette's clear glass balustrading was the ideal solution. It also provided the added advantages of an attractive, transparent and low-maintenance protective barrier.

"We had areas requiring curved glass railings and an area where the railings were on a slope," explained RJ Leighfield's Contracts Director Mark Stratford. "Our client wanted to provide a safe environment for their children, so they couldn't fall off the retaining walls, without losing the view of the garden whilst sitting on the patio."

Other types and styles of railings were considered - the original choice being stainless steel posts and wires, like boat railings. "But the client changed their minds. They wanted something they could see through that didn't obscure the view of the garden," continued Mark. "We advised the

client that post and wire railings were climbable by their small children and wouldn't be very safe."

Following consultations with the client, the Balconette product was chosen as 'the best product at a



reasonable cost'. Then after an initial survey by the installer, Balconette's technical team drew up the design.

"The installers were very knowledgeable and supportive," said Mark, "and Kevin Cranham, Balconette's consultant, was very helpful all through the process. The product seems to be of the high quality we would expect."

For Mark, 'quality of product and level of service' were important aspects of Balconette's offering. He also praised the team for keeping him informed of progress between the placing of their order and delivery/installation.

He added: "It was the first time we had used Balconette and we were reassured by their professionalism. We would definitely use them again."

Balconette adds 'wow factor' to Scandia-Hus Show Home

Two clear glass balconies supplied by Balconette fitted the design brief perfectly for Scandia-Hus, adding the 'wow' factor to the Swedish self-build home supplier's Adelia Show Home at its East Grinstead headquarters.

As the property's modern design incorporated an external balcony and extra-wide Juliet balcony from the start, it was important to Scandia-Hus to find a supplier that could provide matching products, even though the Juliet was a bespoke size at 4.8 metres wide.

"We had used Balconette previously and they were already a favourite with our clients," commented Jeffrey Willis, Scandia-Hus Project Manager, "we wanted the best product that was available for our Show House. We considered other companies, but Balconette's product quality stood out."

Balconette's ability to meet the exacting technical challenge was a key aspect of their offering for Scandia-Hus.

"The most difficult part by far was the extra-wide Juliet balustrade to the master bedroom which necessitated the incorporation of two posts," continued Jeffrey. "This was a very technical challenge as the positioning of the post supports had to be done



... "we wanted the best product that was available for our Show House. We considered other companies, but Balconette's product quality stood out."



early on in the build and had to be 'millimetre' perfect."

He judged both quality and cost as 'first class', saying that the balustrades help to give their Show House the 'wow factor'.

Concluding, Jeffrey added: "Balconette certainly delivered our requirement for a contemporary low profile glazed balcony balustrade and bespoke Juliet balustrade. We would have no hesitation recommending them to our clients. We are very happy with a job well done!"

For more information on the Scandia-Hus Adelia Show House visit www.scandia-hus.co.uk

Exclusive homes showcase new Frameless Juliet balconies from Balconette

Designed and built to exacting high standards, two exclusive newbuild detached homes in Harberton Mead, close to Oxford city centre, are among the first to showcase new Frameless Juliet balconies, supplied and installed by Balconette.

Providing the required safety and support without the need for a handrail, the frameless system's minimalist appearance perfectly complements the contemporary style of the six-bedroomed properties built by privately-owned developer Rectory Homes.

The £2 million-plus luxury homes also feature external balustrading using the highly-regarded Balcony 2 System with its aerofoil-shaped handrail adding a further distinctive architectural statement.

Tony Wrench, Procurement Manager at Rectory Homes, said: "Glass balustrading was a specific request for these top-end properties and Balconette fitted the bill. The balconies have been well-received and look fantastic; we are very pleased with the end result."

In recommending Balconette, Tony added: "If a glass balustrading or frameless system is required on a future project, we would use the company again."



Installation is straightforward using attractive support profiles secured to the walls either side of the aperture

Designed to enhance the external appearance of any building, Balconette's frameless Juliet balcony uses 21.5mm laminated and toughened glass panels. The system allows for a frameless Juliet of up to 3.15 metres in width as a single sheet of glass.

Installation is straightforward using attractive support profiles secured to the walls either side of the aperture.

These profiles allow tolerances for installation where previously very accurate drilling was required for glass with pre-drilled holes.

Balconette stocks seven standard sizes of its frameless glass Juliet balconies, ranging from 1280mm to 2840mm, which are available within five working days.

With nothing to obstruct the view, this cleverly-designed system delivers a 'clearly' stunning and eye-catching result.

Nothing obscures the view with a Frameless Juliet



From modest maisonettes to multi-million pound mansions, Balconette's Frameless Glass Juliet balconies are ideal for all types of properties, combining maximum ingress of light with minimum maintenance.



They also retain completely clear views to the outside, which was exactly what the owner of this luxury newbuild property in the Midlands wanted from his first-floor study.

"He's very impressed and described it as a 'beautiful product'," commented Paul Nelson, Contracts Manager of The Window Centre, Solihull. "He particularly likes the clean lines and simplicity of the design, which do not obscure the view over the garden."

Installation of the 2840mm-wide Frameless Juliet was straightforward, according to Paul, who added: "We couldn't fault the service and delivery we received from Balconette."

Balconette's products fully exploit Isle of Man views

Fantastic panoramic views of the southern tip of the Isle of Man from a luxurious bed and breakfast property are fully exploited using every product from Balconette's wide range of low-maintenance clear glass balustrading, Juliets and curved sliding patio doors.



Owners Philip and Jillian Routledge specified Balconette's four-panel curved patio door, with two sliding panels, that forms the stunning centrepiece of the domed guest lounge at The Arches overlooking Port Erin. Either side of the curved white aluminium powder-coated doors are two further straight patio doors allowing additional access to the outside space.

Forming a semi-circle that measures 8.4m in girth, maximising the 180-degree views, the curved door has 28mm Low-E toughened double

glazed units. It opens onto a square terrace with a frameless structural glazed balustrade, also supplied by Balconette. This balustrading style was chosen specifically to fulfil safety requirements with low-maintenance minimum visual impact, plus the added benefit of protection from prevailing winds.

The curved patio doors and balustrading elements were installed by Chris Wedgwood, Managing Director of Jurby-based Hamilton Project Management Ltd and

incorporated as part of extensive remodelling to the substantial 1920s building, perched on a steep site in Tower Road.

Five years of construction work included rebuilding and extending the southern elevation and roofing over what was an outdoor swimming pool.

Following the shape of a second lower terrace next to the swimming pool are nearly 40 metres of Balconette curved and straight balustrading, topped with Balconette's proprietary Royal Chrome anodised handrail.

“It’s so central to what we wanted to achieve. There’s no product like it and it really brings the outside in!”

Above this terrace, three glass Juliet balconies supplied by Balconette maintain clear views from guest rooms on two upper floors.

Having holidayed on the Isle of Man for many years, the couple moved there from the UK in 2006 having fallen in love with The Arches’ spectacular coastal location. The B&B opened for business in 2011.

Philip, from Liverpool, explained: “The incredible views inspired all the glass as the whole point was to maximise the pleasure from them.

It’s unusual to have 180 degrees of such splendour – and the curved patio door from Balconette really does it justice. Everyone is stunned when they see it and it adds so much to the value and enjoyment of the property.

He added: “As the house is located near to the sea, that’s great for the views but a real challenge to the materials used to enable us to enjoy them to the full. After four or five years of installation, the finishes on our Balconette products are like new.



“The curved patio door performs well; it’s thermally-efficient, air and watertight, even during the wild weather we get sometimes. It’s so central to what we wanted to achieve. There’s no product like it and it really brings the outside in!”

Project architect John Cryer, of Marshall Cryer Architects said an initial triangular design for the lounge was adapted into a more space-efficient curve after consultation with Balconette.

He said: “The curved door is a remarkable product, making the most of the space and views while turning an ordinary room into something

much better. This site is so suited to this product. So many sites on the island have good views that would benefit from products like those from Balconette. I would definitely use their products again.”

According to Chris Wedgwood, it’s the combination of Balconette’s three different products that work really well at The Arches. “The curved patio door undoubtedly gives the house its ‘wow factor’ and makes the most of the views. The structural glass balustrade is a fantastic answer for uninterrupted views. They’re all good quality, well-thought out products.”

“The curved patio door performs well; it’s thermally-efficient, air and watertight, even during the wild weather we get sometimes.”

Breakthrough product: The Balcony 2 Infinity Screen

There are no limits to the way you can integrate this innovative system into your design; you can move your balustrade from the regular 1100mm height to taller glass seamlessly



Stylish, Stunning and Unique: Exceptional Innovation for Glass Balconies and Balustrades

True advances in balconies and balustrading are rare, so we're very excited to present a breakthrough innovation, unique to Balconette.

For too long, customers have had to compromise their designs for the sake of privacy and safety. Adding a privacy screen or extra height to regular glass balustrading has meant giving up on that perfect design.

Extra posts and a network of support railings meant extra work for the fitters and an appearance out of keeping with high expectations.

But that's all history now. Balconette's team of design engineers have worked tirelessly to create a pass through glass balustrade that effortlessly complements regular glass balustrading.

With frameless glass above handrail height, your balconies and balustrades will look slick and provide privacy, safety and protection from the elements without compromise.

At last, projects that demand high impact aesthetics can find a solution that suits. There's no need for clunky posts or rails interrupting the flow of a building or obscuring a beautiful view.



The Infinity Screen displayed here as a privacy screen.

Technological Breakthrough

Despite its ground-breaking appearance, this unique pass through glass balustrade system works very simply. Instead of being supported by a network of angled rails and posts, it cuts straight through the aerofoil handrail.

The 10mm thick, toughened and satinised glass slices straight through the handrail and is secured in a clamp at the base. This eradicates the need to secure the top of the screen with railings or posts above handrail height.

The stability of this method means that fewer structural posts are required compared with conventional privacy screening; it's also simpler to fit and plan, and has dashing good looks.

Beautiful Simplicity

Your glass balustrade should complement your project and surroundings, it shouldn't be the focal point on your balcony or in your garden. That's why we've worked hard to create a screen that blends in seamlessly with our conventional glass balustrade system.

There are no limits to the way you can integrate this innovative system into your design; you can move your balustrade from the standard 1100mm height to taller glass seamlessly, with simple planning.

Everything above the handrail is frameless, so whether you choose privacy glass or clear glass, you'll appreciate the simple and stylish way this balustrade complements your project with its minimalist good looks.



Here the Infinity Screen system is used around the entire balcony giving a clear view whilst being as simplistic as possible.

And the beauty of this system isn't limited to good looks. With a maximum length of 2250mm without posts and 1500mm between posts, once they're incorporated into the system, there are fewer posts to install meaning less hardware to maintain.

And if you add the BalcoNano® self-cleaning coating to the glass, even cleaning your Infinity Screen glass balustrade will be simplicity itself.



Make it Yours

Complete your project with your perfect Infinity Screen system. Choose from either Silver Anodised or Royal Chrome finishes for the Aerofoil handrail - both guaranteed for 10 years, and take your pick from our full choice of glass tints - clear, blue, bronze, green, grey and satin.

Make your life easier by adding the easy-clean BalcoNano® self-cleaning coating; especially useful if your glass balustrade or balcony will be used for a swimming pool or hot tub, or is planned for an exposed location.

Call Balconette now and add one of these unique and breakthrough Infinity Screen glass balustrades to your project today.



For housebuilders, contractors and property developers

Kerb appeal is vital when it comes to new properties and our products can help you in this regard. Balconette's clear glass Juliet balconies, balustrades and patio doors provide a modern, eye-catching flourish that enhances the architecture of both residential and commercial developments.

Over the years we have built up a deserved reputation, not only in terms of the design options provided by our innovative materials, but also for ongoing customer support, advice and help in overcoming technical issues.

Backed by this considerable experience and a first-class track record of working with developers, we can meet the specific requirements of projects of any scope or size and offer the materials and designs that overcome the problems associated with traditional materials such as stainless steel, iron and timber.

In doing this, we have demonstrated the concept of truly affordable glass balustrades; combining a very good deal on the initial purchase price with the long-

term cost-saving compared to traditional materials. Our products are low-maintenance, being resistant to corrosion and rot, and save on painting and repairs, including our BalcoNano® protective glass coatings.

We can supply custom-made or standard sized configurations and finishes to meet your specific requirements. Installation is straightforward, with technical queries dealt with promptly and quickly resolved.

Furthermore, our ability to provide a snap-and-pop service with a short lead time and prompt delivery, plus on-site assistance with fitting and installation if required, is valued by many clients.

Full ongoing technical support from start to finish provides complete assurance on the project, from

programming and design, technical drawing and load tests to technical specifications and structural calculations.

The aesthetic contribution our products and service can bring to the appeal of your finished project can be witnessed in the many schemes we have completed throughout the UK - and beyond. Be assured, our customer testimonials bear testament to client satisfaction.

Meanwhile, if you have any questions, please tour our website or, better still, get in touch and we will be pleased to help. We welcome individual enquiries from installers, quantity surveyors, builders and developers. And if you want to see our factory and products first-hand we will be pleased to welcome you.

19 Balconette curved door makes the connection at Hardy's Birthplace Visitor Centre

An impressive concave sliding patio door installed at the Thomas Hardy Centre in Thorncombe Woods at Higher Bockhampton.

20 Balconette's curved door offers commanding sea views at Battle of Britain Memorial Centre

19 metres across by 2.55 metres high this is one of the largest Balconette curved doors.

22 Balconette contributes to 'a Grand Design on an epic scale'

Curved doors and balustrading help to create a 'great sense of theatre' at a spectacular residence in West Sussex.

24 Glass Juliet balconies – what they can do for house builders

Balconette glass Juliet balconies make an impact in Cambridgeshire, Denham, Lesmahagow and the Falkland Islands.

27 Balconette delivers excellence for 377 balconies in London

Clear glass balconies are a striking architectural design feature of the landmark Baltimore Wharf development in London's docklands.



Balconette curved door makes the connection at Hardy's Birthplace Visitor Centre

An impressive concave sliding patio supplied by Balconette is making the right connection for visitors to Dorset discovering more about the life and works of one of the nation's great authors and poets, Thomas Hardy.

Measuring more than five metres across, the four-panel door has been installed at the £1 million Hardy's Birthplace Visitor Centre at Thorncombe Woods at Higher Bockhampton, near Dorchester, close to the cottage where Hardy was born and wrote some of his early novels.

The centre, officially opened in March 2015, aims to provide visitors with more information about the novelist and the landscape that influenced his work. Mr Angus Campbell, Lord-Lieutenant of Dorset is pictured at a 'ribbon-cutting' ceremony at the centre.

The project, which secured a £525,000 grant from the Heritage Lottery fund, is a joint partnership between Dorset County Council and the National Trust.

Balconette's curved door was specified by project architects White Design Associates Ltd of Bristol so the building and its use could 'engage with the natural landscape'. Balconette's BalcoNano® factory-applied self-clean glass coating was also specified for the clear double-glazed units to reduce the amount of cleaning.

Commenting on the door and its unique concave shape, Project

Manager David Crudgington of Dorset County Council's Dorset Property, said: "It's great and does the job exactly as it is meant to. It fits the space very well and is part of the visual link between the inside and outside. This connection fits the design brief perfectly."

David, who oversaw the design and build of the centre on behalf of the County Council and the National Trust, said the curve was an integral part of the multi-functional building's design so that visitors could enjoy views of the woodland beyond and enjoy seamless access to the outside terrace.

"The door is a key connecting feature with the woodland and its beautiful bluebells that come very close to the building. White Design looked at several options but Balconette came up trumps," he said.

"The facilities were badly needed as they didn't exist before. The building has been very well-received by the public and is proving to be a very popular refreshment stop – with the added 'wow factor' of a fantastic and practical curved door leading out onto a terrace," added David.

The visitor centre's one large room combines several functions; a 'meeting

and greeting' area, an educational space, shop, café and workshop for the Dorset Countryside Rangers and woodland workers.

Sarah Key, who runs the Under the Greenwood Tree café, said many visitors have admired the door, adding: "It looks lovely and really brings the views inside. It will be great to open up on hot sunny days, so we're looking forward to summer!"



Balconette's curved door offers commanding sea views at Battle of Britain Memorial Centre



One of Balconette's largest-ever curved sliding glass doors has been installed at a new £3.5 million visitor and education centre dedicated to the Battle of Britain overlooking the English Channel in Kent.

The cliff-top site at Capel-Le-Ferne near Folkestone is dedicated to Churchill's famous 'Few' who fought in the skies overhead to keep Britain from invasion.

Comprising ten curved panels and measuring 19 metres across by 2.55 metres high, the Balconette door is a striking design element at the Battle of Britain Memorial Trust's new Wing building where it provides commanding panoramic sea views from the first-floor Cockpit Café.

The Wing, which is home to the interactive Scramble Experience, was officially opened by Her Majesty The Queen and the Duke of Edinburgh in March 2015 during the 75th anniversary of the Battle of Britain.

The iconic building takes its name – and its unique shape – from the wing plan of RJ Mitchell's best-known fighter, the Supermarine Spitfire – one of the two aircraft credited with doing the most to win the Battle of Britain in 1940.

The building echoes the Spitfire's uplifted wing shape, while the curved door resembles the aircraft's cockpit windows – looking directly across to France from where enemy aircraft would have appeared 75 years ago.

The building's architectural designer and specifier, Nick Lawn, partner at Folkestone-based Godden Allen Lawn, commented: "The door looks fantastic with 180-degree views of the sea; you couldn't ask for a better location for it. When the four sliding panels are fully

open, the eight-metre opening really connects with the outside terrace, which is just what I wanted."

Praising Balconette's technical expertise and help with the concept, he added. "What I particularly liked was the door's ease of operation and it was valuable to see this first-hand on a similar installed door which their team showed me at the specification stage. The installation process all went very smoothly and I would work with Balconette again. It's been a great project!"

The building echoes the Spitfire's uplifted wing shape, while the curved door resembles the aircraft's cockpit windows

The Wing was constructed over 18 months by main contractor Epps Construction Ltd. Project Manager Nick Hamer said: "The door looks impressive and it's a very good system, the door operates really well which is very important in a public building. The product is top-notch and you can't fault it at all. We would definitely work with Balconette again."

A spokesman for the Battle of Britain Memorial Trust said: "The Wing is built in the shape of a Spitfire wing, with a central 'cockpit' area on the first floor housing a café with unbeatable views out over the channel.

"The café's curved glass doors, which lead out on to a large balcony, allow visitors to enjoy the view even when the weather is bad. They can easily be slid back during good weather to allow access to the great outdoors and they lend real style to the building," he added.

Effi Wolff, Managing Director of Balconette concluded: "The curved door forms a spectacular central feature at this iconic national memorial building which will be visited by thousands of people every year. So understandably before placing an order for such an important part of the building, the client wanted to see a similar installation and learn more about our innovative and specialist curved door system.

"We were happy to show them a uniquely-designed property with curving shapes that feature several of our curved doors, including a large six-panel door. The products' function, aesthetics and our ability to deliver on a significant bespoke scheme all really impressed the team and their order soon followed.

"At 19 metres wide, this is certainly one of our largest curved doors and it looks absolutely amazing! The Battle of Britain Memorial Trust's Cockpit Café must have one of the best views in Kent and we are delighted to have helped the client realise their vision with this prestigious project."



"The door looks fantastic with 180-degree views of the sea"



Balconette contributes to 'a Grand Design on an epic scale'

Nestled in the West Sussex countryside, this spectacular new residence built by developer Lodgecrest and main contractor Southgold exudes a 'great sense of theatre' with dramatic curving shapes enhanced by curved patio doors and balustrading supplied by Balconette.

Named Eclipse after its slim curved shape, the striking two-storey property stands in over eight acres on the site of a former piggery near the village of Slinfold and enjoys open panoramic views across its grounds. It is valued at £2.5 million.

Maximising the views and light to accommodation on both floors are 14 concave or inwardly-curving patio doors, including an impressive six-panel door in the spacious upper ground floor kitchen/family room. Outside, more than 26 metres of curved balustrading using the Balcony 1 system with a shiny chrome circular handrail follows the sweeping balcony overlooking the secluded 'sunken' courtyard.

Directly below, a series of concave curved glass doors create a stunning visual impact to the lower bedrooms and games room, allowing in much

natural light to the interior and direct access to the courtyard.

The inclusion of an ambitious curved design was a first for South East-based Lodgecrest, as Director Richard Kelly explained: "The original plan to feature curves throughout the building was conceived through collaboration of architects' ideas; it's a bespoke design with hardly any straight walls."

Maximising the site's potential presented a key challenge. This was achieved by constructing the building elements below and above ground to minimise the property's impact on the rural landscape and to comply with planning constraints.

"There's a bridleway and public footpath alongside its boundaries, so it was vital to achieve a low impact within its country setting," said Richard. "You can only see the true curvature when close up to the building."



Acknowledging that faceted glass would have been less expensive, Richard felt it would have 'taken away one essential element of the building'. Having found Balconette via a Google search and researched the company's expertise in curved glazing, Lodgecrest engaged them on the project.

Richard continued: "Balconette could manufacture what we needed to suit the building's unique and striking design. Their team fulfilled our requirements to have a complete elevation of smooth curved glass and supply all the required elements, including the curved balustrading.

"It was the first time we'd attempted a curved design and the first time we had worked with Balconette. The quality of their products is very good and I think they look smart. I also liked the design; for example the precise construction of the bottom balustrading rail."

In conclusion, Richard said: "Underneath its sedum 'green' roof, the property gives a hidden feeling and does not reveal its dynamic interior and lower courtyard until you enter and walk through. The view opens up like a surprise and the whole house has a great sense of theatre.

"Using Balconette's products has helped to give Eclipse its full 'wow factor' and I would certainly use the company again," he added.

For Southgold, a South London-based family-run construction company, a good working relationship was quickly established with Balconette with whom they'd not worked with before.

"Initially a lot of trust is involved from both sides, especially with a 'big ticket' item such as this project. Yet you only need one successful project to build up that trust," said Gavin Bradley,

*“ . . . a Grand Design on an epic scale . . .
The curved glazing looks fantastic and
when installed it changed the look
of the whole project.”*

Southgold’s Contracts Manager, who was impressed with Balconette’s professionalism.

The challenges presented by the building’s curved shape meant it was important to find the right specialist supplier that could fulfil the design elements. Of the three quotations sourced by Southgold, it was Balconette’s competitive price, their service and location close to the project that were key to securing the contract.

Gavin continued: “We were invited to their Lingfield showroom where we could see their balustrading and curved door products and to discuss the project’s requirements. Throughout the project, they stuck to their price and did what they said they would do.”

Praising Balconette’s service, he said: “Given the bespoke nature of the products, we were a little nervous about the installation and keen to get it right. The technical support on site

was fantastic; we were very happy and it’s all been really good. We would recommend the company and have already done so to another contractor.”

Commenting on Eclipse itself, Gavin described it as ‘like a Grand Design on an epic scale’, saying: “The curved glazing looks fantastic and when installed it changed the look of the whole project. Without it the curve would not have looked as natural as it does. It’s great to have it in our portfolio!”

In conclusion, Gavin added: “Eclipse threw up different challenges for all involved. We needed to form new working relationships with companies having experience in curved designs. Knowing specialists like Balconette who can deliver on projects like this is critical. A lot of suppliers might not live up to expectations, so it’s great to find the companies who can.”

*“Using Balconette’s products
has helped to give Eclipse its full
‘wow factor’ and I would certainly
use the company again.”*



Glass Juliet balconies – what they can do for house builders

Shattering the concept that ‘glass is expensive’.

For house builders and developers, installing low-maintenance glass and aluminium Juliet balconies instantly solves many of the problems associated

with ‘traditional’ material choices such as stainless steel, iron or timber.

Firstly, cost saving is a major factor. Glass Juliet balconies are not only a great

deal on initial purchase, but also prove to be a long-term cost-effective choice when compared to conventional balustrading materials as their corrosion resistance

means they don’t rust or rot. You can forget the need for on-going time-consuming painting or repairs.

Balconette’s Glass Juliet balconies are probably the most cost effective products for this specialist market. Breaking the concept that glass balconies are expensive, Balconette’s range of Glass Juliets start from £175.

The minimalist appearance and clear glass that retains views and allows maximum light inside adds to kerb appeal, attracting purchasers and helping developers to sell more easily, especially to discerning buyers.

With more building professionals choosing the low-maintenance, high-aesthetics balustrading route, it may be of some benefit to read about some examples showing how these Juliet balconies have made an impact and worked on the following residential and commercial projects.

March, Cambridgeshire

Architect Chris Cooper of James Developments Company Ltd specified 78 Juliet balconies to enhance the riverside views of 18 exclusive townhouses overlooking the River Nene at March, Cambridgeshire.

Double-sized Juliet balconies are a distinctive feature of the three and four-bed Sandpiper houses, maximising the properties’ light, space and views overlooking private moorings and increasing the appeal of their rural location.

Each of the mid-terraced homes has a total of four Juliets, measuring 1.7 to 2.9 metres wide, with end properties benefiting from an extra set on their side elevations.



“It’s a straightforward product for a straightforward situation . . .”

Commenting on the use of the Balconette system, Chris said: “Key criteria for us was something light in appearance and it had to be completely ‘kiddie-proof’. For example, the balustrading could not be climbed over, nor trap a child’s head. Added to which, the system had to be reasonably priced and fully finished.

“Installation was simple. It’s a straightforward product for a straightforward situation and it has been well-received by purchasers,” continued Chris.

He added: “We are seeing more and more Juliet balconies as ‘standard’ features because as well as being a useful marketing tool, they are attractive and very popular with buyers. In a riverside setting, such as the Sandpiper properties, they give the sense of being on a deck, while at the same time maintaining privacy.”

Balconette’s Managing Director Effi Wolff said “designers have welcomed a low-maintenance system that is not only simple to install, but allows greater freedom of design options.” He added: “Straight or curved glass can be used to create elegant Juliet and external balconies without the need for vertical or corner posts.

“Increasingly, architects are seeking an attractive balustrading solution that combines safety whilst maximising light and spaciousness, but at reasonable cost. The Balconette system does just that.”



King’s Island in Denham

In a large prestigious gated island development at King’s Island in Denham, near London, 180 Juliet balconies in a mix of standard and bespoke sizes were specified for five new apartment blocks by developer Weston Homes.

All the Juliet balconies use Balconette’s eco-friendly BalcoNano® double-sided self-cleaning glass coating to keep the glass looking cleaner for longer, greatly reducing cleaning cycles by up to 90%.

The four-storey buildings, completed in 2012, overlook the Grand Union Canal and River Colne on the site of the former William King Flour Mill close to the M40 and M25.

The balconies were supplied with a Royal Chrome handrail, which replicates the look of stainless steel, and installed by contractors Quality Metalwork Services Ltd on the new buildings and converted original flour mill.

Commenting on the project, QMS Director Adrian Leach says: “It is the first time we have worked with Balconette and their service and delivery were excellent, enabling us to complete phased installations within exacting time schedules. The Juliet balconies were very

straightforward to fit and took just 1.5 hours for each one.”

Balconette supplies many of the UK’s major house builders. Introducing the self-cleaning glass coating option has further increased the products’ appeal.

“We are seeing continuing demand for our low-maintenance, competitively-priced products from house builders of all sizes,” commented Effi. “Our BalcoNano® self-cleaning glass coating is now an almost universal client choice.”

Balconette’s Juliet balconies also deliver great results for bespoke refurbishment projects. Castleoak, a leading care sector development and construction company, specified clear glass Juliet balconies for one of its care projects to make the most of magnificent lakeside views in South Lanarkshire.





Lesmahagow, Scotland

Balconette's product met the architect's precise balustrading specification for French Doors in 20 remodelled extra care apartments at The Retreat, Auchlochan Retirement Village near Lesmahagow, south of Glasgow.

It is the first time Balconette had worked with Castleoak, whose project in Scotland was its thirteenth for MHA, one of the UK's leading not-for-profit care providers. The project

"Working with Balconette was straightforward. All of the technical questions were quickly answered and telephone calls returned immediately."

also involved the refurbishment of the previous atrium area into a communal lounge and four premium apartments on the second floor.

Castleoak Project Surveyor Sean Coyle said the Balconette product was chosen as it matched the architect's design and allowed light into the property, whilst retaining unrestricted views across the lake and landscaped grounds.

He commented: "The Juliet balcony system worked on our building extremely well.

Auchlochan was the first project where we used the Balconette product and after Balconette provided a quotation during the estimating process, it was a natural progression to follow this through to an order."

Sean added: "Working with Balconette was straightforward. All of the technical questions were quickly answered and telephone calls returned immediately."

Stanley, Falkland Islands

In what is one of its remotest projects to date, Balconette has supplied glass Juliet balconies to The Waterfront Hotel in Stanley, capital of the Falkland Islands.

The bespoke balconies were shipped to the islands, which lie eight thousand miles from the UK in the South Atlantic Ocean.

Each one measures 2,775mm wide and features Balconette's proprietary Royal Chrome handrail. They were installed in front of patio doors in the boutique hotel's restaurant overlooking the harbour, as part of refurbishment works at the eight-bedroomed hotel.

Luis Romo of The Falkland Islands Company Ltd, who placed the order, explained: "Balconette was the only company to give us a quote and the only one which took any interest in supplying us with the product.

"All the logistics were taken care of by our UK office and we were

very pleased with the service from Balconette. The balconies were installed in early January 2014, arriving three months by ship after placing the order."

The owner of the hotel, Alex Olmedo specified a glass balcony to give an unobstructed view of Stanley harbour as well as to provide an aesthetically-pleasing secure barrier when the doors are open.

He said: "We're very impressed with the final results and have achieved the modern and commercial look we were after. The building now looks stunning."

Effi Wolff, Balconette's Managing Director added: "We supply our products worldwide, but the Falkland Islands is probably the furthest place so far. As our products are made from corrosion-resistant materials, they are ideal for coastal climates. We were delighted to help and hope the hotel staff and their guests derive many years of enjoying the views from their Juliet balconies."



Balconette delivers excellence for 377 balconies in London

Balconette developed a custom glass balustrade solution for 377 balconies, realising the architect's original vision for this expansive project and in addition created an amazing £500,000 saving on the original design.



Clear glass balconies are a striking architectural design feature of the landmark Baltimore Wharf development in London's docklands.

Breathing new life into the former London Arena site, Baltimore Wharf is an exciting and ambitious £150 million mixed development comprising private and affordable housing, retail, leisure and community facilities. Designed by architects Skidmore, Owings and Merrill Inc., it is among several significant construction projects in the Docklands area being undertaken by international developer, Ballymore Group.

Phase One of the Baltimore Wharf development, which includes more than 600 apartments in five separate residential blocks, is constructed on the 6.8 acre former entertainment site which is across the water from Ballymore's 50 storey, neon-lit Pan Peninsula residential development.

As a key architectural feature of the buildings' external facades, the design and installation of the external balconies required a particularly considered and inventive approach.

Working closely with the architect, developer and steelwork contractor, Balconette developed an elliptical handrail and bottom rail system that created a bespoke 21st century balustrade solution to suit the requirements of the multi-storey buildings and, just as importantly, the £3 million budget.



Balconette also developed and supplied two unique extruded aluminium fascia profiles that finished off the edges of the balconies, one of them being a 295mm wide extrusion. The designed system enabled a balcony system solution which included frame cladding, decking and balustrade, delivered flat-packed, complete to site and ready to install.

The original design had called for a structural glass balustrade to be fitted on top of the steel balcony structure; this design required that the balcony steel be almost 300mm in depth.

Balconette offered a design that allowed the balconies to be made with no vertical posts using a system that is less in height, lighter in weight, clearer in glass colour and one that created a saving of £500,000 from the original design.

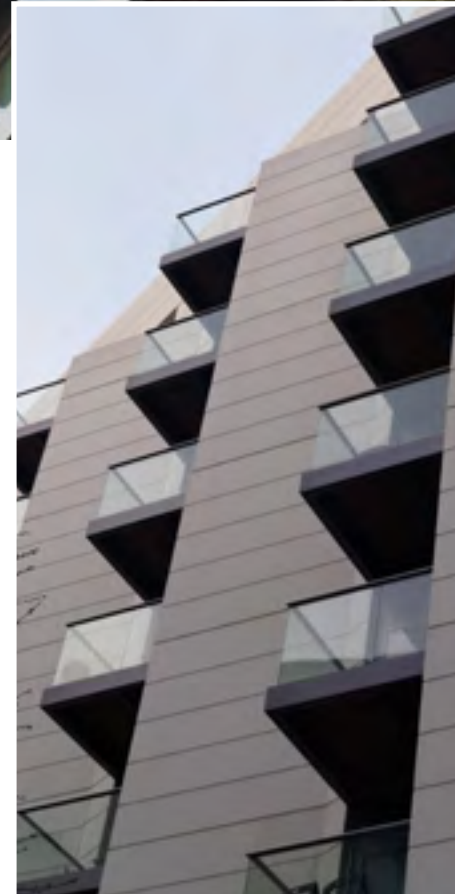

"Balconette's experience and ability to design new sections and adapt them to specific projects opens up a large expanse of design possibilities that can be realised"

The hand-railing was designed to take the load to provide all the required strength and support and meet all the relevant Building Regulations. Utilising the handrail allowed the balustrade to span the required lengths without the need for vertical posts.

According to Effi Wolff, Managing Director at Balconette, the ability to meet the architect's original balcony design criteria - to present a perfectly flat front fascia to seamlessly fit the main steel and the glazing track - was of fundamental importance.

A new aluminium handrail, finished in Royal Chrome to look like shiny stainless steel, and lower track extrusion was specially designed for the Baltimore Wharf apartments. This allowed for relatively simple fitting to the main steelwork.

“Balconette offered a design requiring no vertical posts, was lighter in weight, clearer in glass colour and created a saving of £500,000 from the original design”



Cost engineering through innovation

As well as supplying 377 balconies for the project, a cost effective design was realised for the social housing area of the development, replacing the wrought iron original design with a glass balustrade that matched the budget.

In conclusion, Effi says: “Balconette’s experience and ability to design new sections and adapt them to specific projects opens up a large expanse of design possibilities that can be realised. We like to get involved at the outset and can help drive the design to meet the requirements by being innovative and budget aware.”

Whether made of stone, wood or cast iron and now glass, balconies are an enduring and popular building feature that has been with us for centuries. Their design has continued to evolve to meet the changing face of architecture. The Baltimore Wharf project represents another step forward in the evolution of balcony design, taking it firmly into the 21st century.

Feature fascia

“Clear structural glass was originally specified. However, our solution using toughened and laminated 9.5mm glass to retain a clear view without the need for posts and at a very competitive price satisfied the key requirements for this prestigious project,” he says.

“What is new about the system is that Balconette has provided a flush-fitting anodised extruded aluminium feature fascia which provides a detail to match the

main buildings’ window frames. This hides the steel balcony supports presenting a neat front face to the structure.”

Effi suggests that what has made the design concept such a success was ‘going the extra mile’ to ensure that the original vision of the architect was maintained during the design period.

This was achieved through close collaboration with the architect, developer and steelwork contractor from the early planning stages to meet the challenges of

making the design work with no posts and to keep the structure down to a minimum. Measuring 3 metres x 2 metres and 2.3 metres x 2 metres, the balconies did not require any posts.

An added advantage of the system - particularly for high-rise buildings - is that panel replacement, if needed, can be done quickly and safely from inside. Panels are supplied up to 1.2 metre in length for ease of transportation and installation.

Why choose Balconette products for your Refurbishment Project?

Breathing new life into your home or building can be a very rewarding experience. Whatever the size or scope of your refurbishment project, Balconette can supply a flexible range of options that can help you to transform your property and, just as importantly, without breaking the budget.

Many years of expertise and technical innovation have been invested in our products to provide practical, highly-attractive and affordable renovation solutions for all types of buildings - with the added low-maintenance benefit to suit modern lifestyles.

Whether you are undertaking internal or external renovations, converting the loft or installing new decking, balconies, windows or doors, we can offer a wide and flexible range of options to suit your individual requirements and help you realise your vision.

Not only that, we can also assist you with the design and technical specifications, structural calculations and even the choice of finishes and colours, should you require extra support with your plans.

The aesthetic appeal of Balconette's products are showcased in our completed projects and customer testimonials featured in the following pages. They may even help to give you some ideas for your own refurbishment schemes.

The quality, strength and durability of products are complemented by timely deliveries and straightforward installation to keep your project right on track. You can also call on our full technical support and a nationwide network of installers should you need assistance.



Having helped thousands of customers on their 'refurbishment journey', our aim is to make the whole process as smooth as possible from concept to completion.

We hope you will be inspired by our completed projects featured in the following pages. Please feel free to ask any questions you may have and we will be pleased to answer them. You can take a tour of our website, email us, give us a call or even arrange to visit our showroom and factory to see our products first-hand.

31 **Worthing residents specify Balconette for their new smart and contemporary balconies**

Apartment block transformed by glass balconies during major refurbishment project.

32 **Balconette brings back beauty to The Leys**

Low-maintenance clear glass balustrades replace 1960s timber-slatted balconies at a complex near Horsham.

33 **Balconette's glass balconies give Purbeck Heights a new lease of life**

Seaside homes get a new lease of life and a smart new contemporary appearance.

33 **New balconies boost appearance and value of London apartments**

46 ageing, high-maintenance balconies and old railings are replaced with new low-maintenance glass balconies and balustrades.

34 **New glass balconies transform riverside apartments**

Balconette balustrading brings the exterior of London riverside building firmly into the 21st century.

Worthing residents specify Balconette for their new smart and contemporary balconies

Two years of painstaking research into the specification of their new balustrading has paid off for residents in a sought-after area of Worthing. More than 217 metres of glass balustrading supplied by Balconette has transformed their apartment block following the completion of a major refurbishment project.

Owners of the 30 apartments, including two penthouses, at Cardinal Court in Grand Avenue are delighted with their building's smart new contemporary appearance. And the system's low maintenance is another welcome benefit.

Tony Foster, Chairman of the residents' management committee, said the old balustrades, constructed of a concrete 'shell' with a half inset glazed panel to the front, were getting 'tatty' and needed upgrading.

"These balustrades had to be painted every four to five years and as scaffolding was required to do this job, it was getting expensive," he explained. "Initially we were just going to get them refurbished and have new glass panels inserted."

Before embarking on the project, Tony researched a number of balustrading companies and recalled: "There were quite a few. I did a lot of research and it was quite time-consuming. It took me around two years!"

The stainless steel offerings were a main concern for the residents. "As we're near the coast, we were worried about corrosion from the salty air. Stainless steel was ruled out as it was deemed too high risk."

Structural glass with no handrail was another option. "However, as we have a number of elderly residents we thought we'd play safe. Balconette's aluminium handrail provides a reassuring visual reference, as well as being corrosion-resistant," said Tony.

Product quality and value-for-money were also key factors in the residents' specification decision. "As an engineer, I was impressed with the engineering quality of Balconette's balustrade," continued Tony. "It's simple, effective and looks good. As we were also under pressure cost-wise, the system also delivered in terms of price for the residents."

The refurbishment project was carried out by Woodmans Construction, an established construction and renovation firm, operating throughout London and the South East.

Woodmans initially removed the old balustrading, which comprised 500mm high concrete upstands supporting old obscure glass panels that were secured by end-of-life metal frames.

"The glass was very old-fashioned and the balustrading system was in desperate need of upgrading," commented Renata Makosz, Woodmans Construction Operations Manager.

"The residents specified Balconette for its low-maintenance balustrading that won't need regular painting and, of course, to provide better views, especially as the top-floor penthouses enjoy far-reaching coastal views."

Having removed the old structures and prepared the asphalt decks to the existing balconies, Woodmans installed

the Balcony 1 system with a circular handrail in Balconette's proprietary Royal Chrome anodised finish. The toughened 10mm glass panels were specified with a bronze tint for additional privacy.

Renata added: "The new balustrading is sharp, modern and the tinted bronze glass really blends with the brickwork. It looks really nice and lifts the building entirely; the clients are really pleased!"

Concluding, Tony added: "Everything has been very good and very positive. The balconies have been well-received and we are pleased with the result. Even residents in neighbouring blocks have expressed interest, having seen the scaffolding and watched the project progress to completion."

The project was fully completed in Spring 2015.



Balconette brings back beauty to The Leys

Balconette was selected from a shortlist of five companies to complete a major balustrading refurbishment project at The Leys, an apartment complex between Hersham and Esher in Surrey.

The original timber-slatted balconies on the 1960s building were replaced with Balconette's low-maintenance clear glass balustrades as part of an extensive programme of external works. The project was completed in summer 2014.

Property management company Wallakers, managing agents for The Leys, chose Balconette based on its competitive tender, references and recommendations. It was the first time they had worked with Balconette and the company's ability to deliver on time and to budget impressed them.

Wallakers Principal Robert Heald cited 'product, ease of working with the team and ability to perform' as key reasons for choosing the company.

The Balcony 1 system with Royal Chrome anodised handrail finish was installed on 18 upper-floor apartments – 122 metres in total. The 24 apartment complex is set in communal gardens that extend down to the River Mole at Walton-on-Thames.



Before



"It has given the whole building a lift and made a big difference."

Robert, a Chartered Surveyor, commented: "What I particularly like about the circular handrail system is its simplicity and how it suits the external appearance of the apartments, which have lovely views to the river and farmland beyond."

He added: "It has given the whole building a lift and made a big difference. I think the residents are very happy with their new balconies."

Balconette's Managing Director Effi Wolff commented: "We particularly enjoy being involved with balcony refurbishment projects; these

projects are very different from the new build balconies.

"There are challenges, both in removal of the old balustrades and incorporating details of the new into a variety of different build types dating back over the decades.

"But above all, we love the transformative effect that refurbishing balconies has on the building. One could almost call it 'construction plastic surgery' – giving old balconies and buildings a facelift while making them safer and compliant with current regulations," he added.



Balconette's glass balconies give Purbeck Heights a new lease of life

After decades of salty sea air and general weathering had taken their toll on balconies at two apartment blocks near Swanage on the south coast, the owners decided it was time to give their seaside homes a new lease of life – and a smart new contemporary appearance.



Achieving this with more than 50 metres of low-maintenance glass balustrading from Balconette has also given them complete peace of mind, according to Phil Warren, the driving force behind the project.

"What set Balconette apart was the company's ability to provide a ten year guarantee against corrosion," says Phil, the Residents' Association co-ordinator. "This corrosion resistance was an important factor in our decision to choose Balconette's glass and aluminium system given the buildings' location in a tougher coastal environment."

Built in the 1960s, Purbeck Heights comprises 18 apartments with extensive southerly views over gardens to Durlston Bay and the English Channel beyond. The original wood and toughened glass panel balustrades were 'beyond the end of their lives' and proving costly to maintain.

Having researched the market, the residents narrowed down their choice to two companies, eventually selecting Balconette based on their product quality, better value for money and ability to deliver on a larger refurbishment scheme.

"Over the two years it took, from negotiating to completing the project, there was no pressure or 'hard sell' from Balconette," continued Phil, "and we felt reassured by their professionalism."

Balconette's specialist installation team impressed him for always having solutions for problems that arose. "Their work was very good indeed, which reflected well on Balconette," says Phil, "and as far as I'm concerned, they did an excellent job".

"There was no disruption and the installation progressed very smoothly. Everyone is very pleased with their balconies, they look fantastic!"

New balconies boost appearance and value of London apartments



Residents of an apartment complex in North London agree that installing Balconette glass balconies and balustrading has added value and improved the appearance of their homes.

The refurbishment project at Oak Lodge Close in Stanmore involved the replacement of 46 ageing balconies and old railings on the two blocks: 23 balconies plus 23 balustrades – mainly around the roof gardens of the three penthouses.

After 40 years, the original balconies were rusting and requiring a lot of maintenance. Having obtained quotes from three companies, the residents' committee chose the Balconette design for its simplicity, aesthetics and ability to match the balustrading specification.

"The combination of the design and reasonable costs helped us to reach the decision. Now that the installation has been completed, everyone has been full of praise for the new balconies and balustrades. Everyone is delighted with the result," commented George Summerfield, Chairman of the Oak Lodge Close Residents Association.

"They are much more modern than the original 40-year-old ones and let in more light, as well as allowing better views from the flats and penthouses. Not only have they improved the exterior appearance of the buildings, but they have also increased the individual value of all the flats, including those without balconies," he continued.

Despite circumstances forcing a change of contractor to complete the scheme, George said the extra support provided by Balconette's team ensured that they stuck close to their initial budget.

Recommending the company and its products, George added: "The people I dealt with were very efficient and helpful at all times. All the final balconies were installed in a very short space of time and the overall result has been most satisfactory."

New glass balconies transform riverside apartments

Proof, if needed, of the transformative effects of glass balustrading is this prestigious London riverside apartment block which has undergone a complete balcony refurbishment using Balconette's products.



The two-year project involved the replacement of existing painted steel and wire balcony railings on 20 apartments in the five-storey building close to Kingston Bridge in Hampton Wick overlooking the River Thames.

Over the past 25 years, corrosion of the original steel railings bolted to the concrete slab balconies had left them unsafe and unsightly, despite costly repainting.

Having approached several companies for quotes, the residents chose the Balconette product for its 'good combination of glass and metal' that could also meet concerns over weight resting on concrete slabs.

Service was another important factor in their choice, as Chris Waite, Director of the Spinnaker Court Residents' Association explains: "Experience in handling larger

projects, such as apartment blocks, was very important to us. Equally crucial was a full-service offer that would co-ordinate all the elements from the planning process and detailed design to installing extras, such as cladding to the balcony slabs."

Chris also specified the fixings to be as close to the edges of the balconies as possible to maximise internal space.

Commenting on the new balustrading, he says: "We wanted a balcony system that would be zero-maintenance, draught-free, safe and robust and look contemporary. And of course, within our budget!

"The Balconette product is innovative and its quality has certainly met our expectations. Not only has the clear glass increased the light coming into the apartments, it has also dramatically improved the view to the outside. Everyone is very pleased and the modern

appearance of the balustrading has helped to bring the exterior of the building firmly into the 21st century."

From start to finish, Chris says the project had been 'complex and challenging to say the least'. Particular challenges included 'forensic' building control attention to the proposed balcony specifications and 'arduous' dismantling of the old balconies.

Completed at the end of December 2015, the full-service scheme was carried out by Wild Wood Installations, one of Balconette's long-established Approved Partners.

For projects of this size and complexity, the quality of the product, while clearly important is not enough by itself, as Chris points out: "The capabilities, skills, experience and can-do attitude of the installer/project manager is absolutely vital. And in this

respect, Wild Wood Installations have stepped up to the plate – to the extent that I would urge anybody considering a refurbishment of this nature not even to consider proceeding without them!"

He adds: "The result has been transformative and the attributes of the new balconies have attracted attention from not only our residents and visitors, but all the neighbouring properties."

Peter Leck, Director of Wild Wood Installations concludes: "Spinnaker Court has been given a smart contemporary appearance, which hasn't gone unnoticed by the neighbours who have been making enquiries!

"Although not without its challenges, we have made this project work and all the residents now have a building to be proud of. It looks fabulous!"

"The result has been transformative and the attributes of the new balconies have attracted attention . . ."

Balconette Technical Section

For architects, designers and specifiers, having certainty in any of the products you incorporate into your designs is essential. You need to have confidence in them too; not just in terms of their ability to provide the right aesthetic, but also in their technical compatibility and structural capabilities and whether they offer sufficient flexibility that they can be tailored to your specific design requirements.

Fully understanding this, Balconette offers you a comprehensive library of information and technical support on all aspects of our products.

Our considerable experience of working with architects and developers on a wide range of projects, combined with state-of-the-art innovations in materials,

opens up myriad possibilities for incorporating the beauty and light of clear glass into your designs.

This allows you to explore an increased flexibility of options as practicalities of structure and construction rise to the challenges in realising the project's vision – and that of your imagination.

Our materials overcome many of the limitations presented by traditional materials such as stainless steel, iron and timber. They are more resistant to corrosion or rot and require less in terms of maintenance, painting and cleaning. Our glass can be supplied with our unique protective coating – BalcoNano® – for longevity and low maintenance.

Allied to all this is a knowledgeable technical department, providing support and technical

advice on subjects relating to design, dimensions, configurations, calculations of loads and stresses and so forth. Any questions you may have are answered promptly and a friendly advisor is never more than a quick phone call away.

It is not possible to include all the details within this format and so the following pages will show some of the standard technical details and specification of the main product range. All technical details are available in electronic format both in PDFs and DWGs.

A tour of our website will provide you with more information but we are always pleased to answer your questions by phone or even to arrange a visit to our factory so that you can familiarise yourself with our products and materials first-hand.



- 36** Juliet Balconies
- Traditional Juliet Balcony System
- Balcony 2 Juliet Balcony System (aerofoil handrail)
- ↓
- 39** Mirror Juliet Balcony System
- Frameless Juliet Balcony System

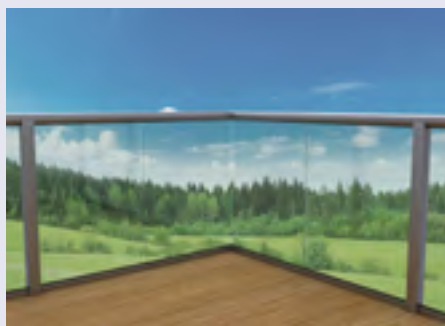

- 40** Glass Balustrades
- Balcony 1 Balustrade System
- Balcony 1 Balustrade System (72 x 72 posts)
- ↓
- 46** Balcony 2 Balustrade System
- Balcony 2 Infinity Screen System
- Balcony 1 Privacy Screen
- SG10 Semi Frameless System
- SG10 Fully Frameless System



- 47** Curved Doors
- Curved Doors Model W2F
- Curved Doors Model W3F
- ↓
- 50** Curved Doors Model W4F
- Curved Doors Model W6F

Traditional Juliet Balcony System



External elevation

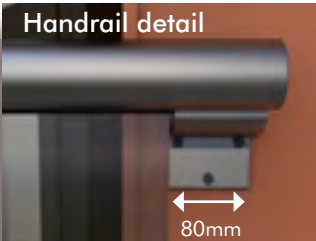

Handrail detail

80mm



Bottom rail detail

40mm

Standard sizes available
1280mm handrail width
1500mm handrail width
1680mm handrail width
1860mm handrail width
2180mm handrail width
2450mm handrail width
2840mm handrail width
3200mm handrail width
Custom sizes available
Min 800mm handrail width
Max 3260mm handrail width

Glass options
Standard models
10mm clear toughened
Custom models
10mm clear toughened
10mm green toughened
10mm grey toughened
10mm bronze toughened
10mm blue toughened
10mm satin (opaque) toughened
Optional extra (for all glass types)
BalcoNano® self-cleaning coating

Free instant quotes
www.balconette.co.uk



Colour options

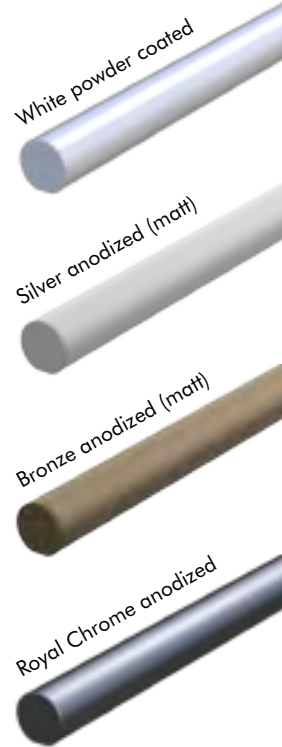

View from inside



3D external view

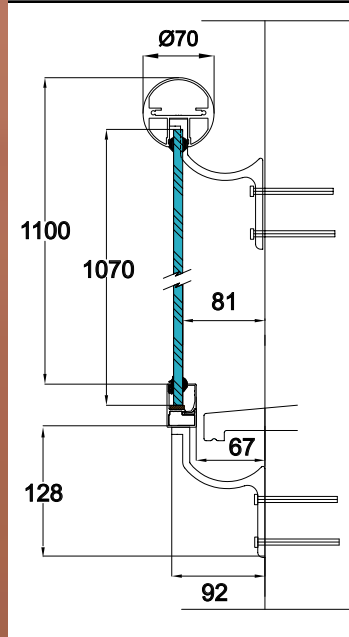

Balcony 2 Juliet System (aerofoil handrail)

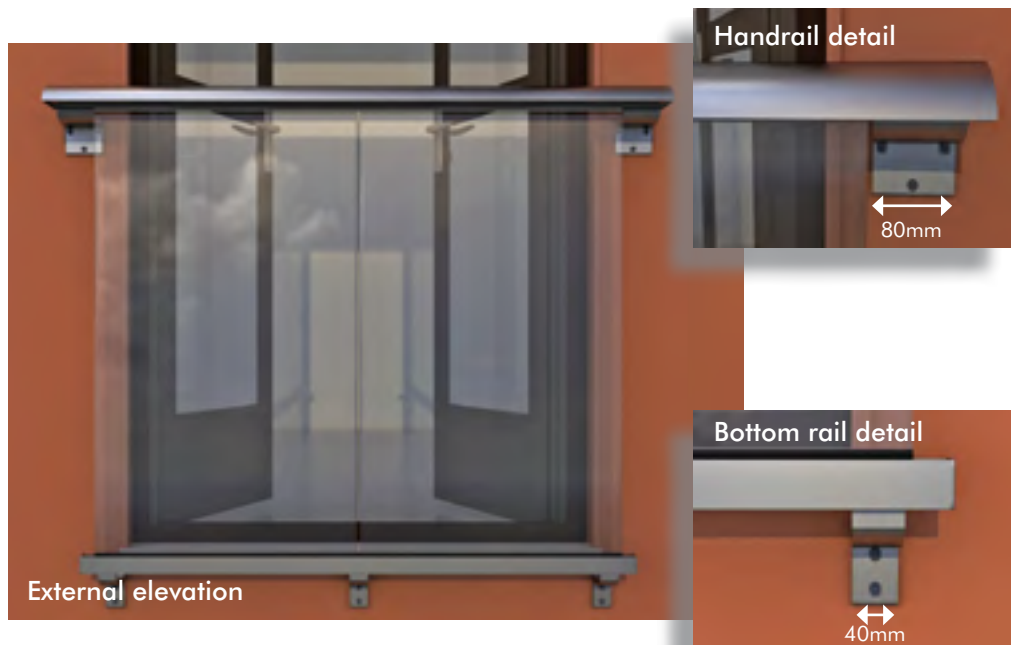

Standard sizes available	Glass options
1280mm handrail width	Standard models
1500mm handrail width	10mm clear toughened
1680mm handrail width	Custom models
1860mm handrail width	10mm clear toughened
2180mm handrail width	10mm green toughened
2450mm handrail width	10mm grey toughened
2840mm handrail width	10mm bronze toughened
3200mm handrail width	10mm blue toughened
Custom sizes available	10mm satin (opaque) toughened
Min 800mm handrail width	Optional extra (for all glass types)
Max 4100mm handrail width	BalcoNano® self-cleaning coating

Free instant quotes
www.balconette.co.uk



Colour options

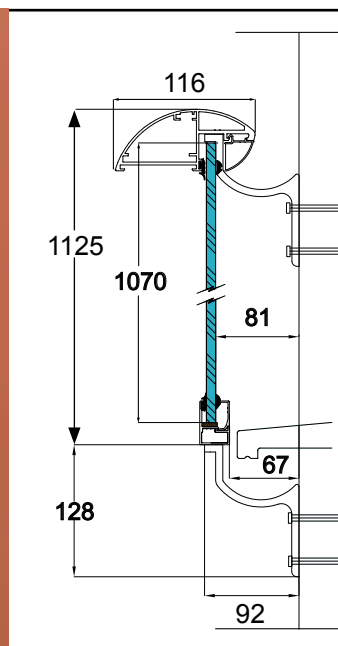
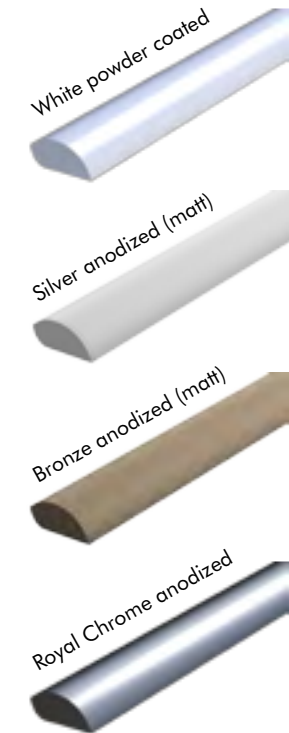

Mirror Juliet Balcony System

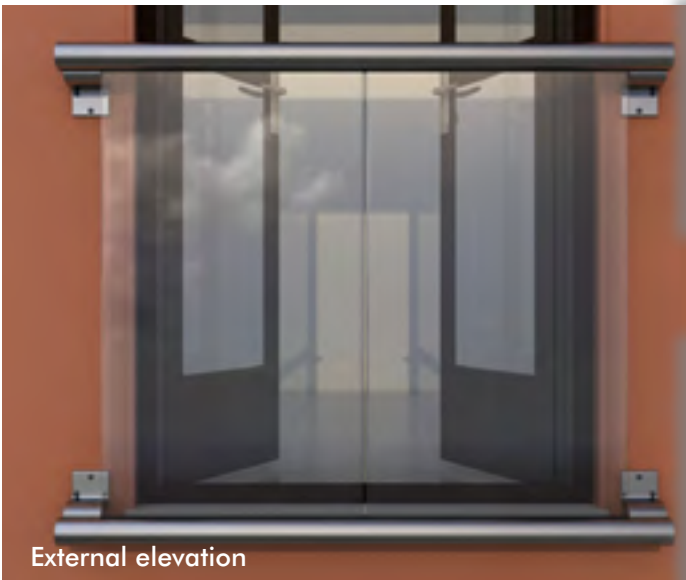

External elevation

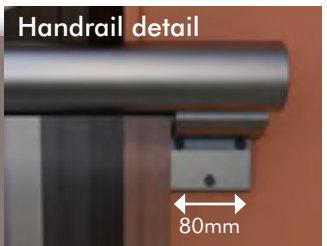

Handrail detail

80mm

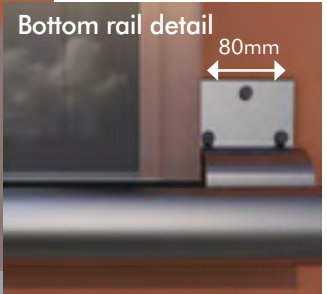

Bottom rail detail

80mm

Standard sizes available
1280mm handrail width
1500mm handrail width
1680mm handrail width
1860mm handrail width
2180mm handrail width
2450mm handrail width
Custom sizes available
Min 800mm handrail width
Max 2450mm handrail width

Glass options
Standard models
10mm clear toughened
Custom models
10mm clear toughened
10mm green toughened
10mm grey toughened
10mm bronze toughened
10mm blue toughened
10mm satin (opaque) toughened
Optional extra (for all glass types)
BalcoNano® self-cleaning coating

Free instant quotes
www.balconette.co.uk



Colour options

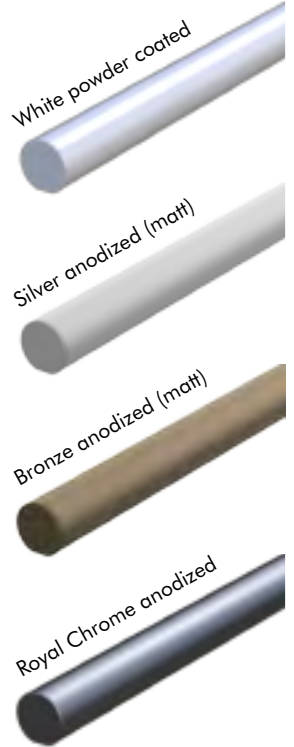

View from inside



3D external view

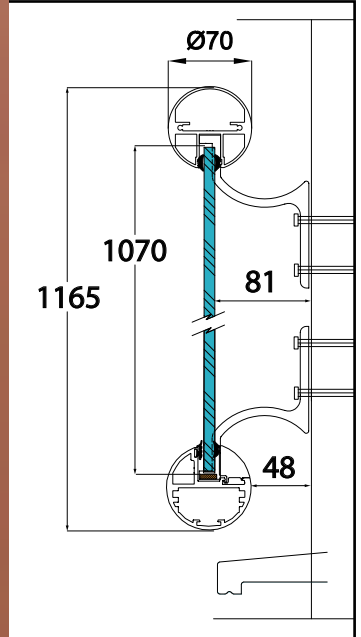

Frameless Juliet Balcony System



Standard sizes available	Colour option
1280mm width	Royal Chrome anodized
1500mm width	
1680mm width	Glass options
1860mm width	Standard models
2180mm width	21.5mm clear toughened
2450mm width	Custom models
2840mm width	21.5mm clear toughened
Custom sizes available	Optional extra (for all glass types)
Min 800mm width	BalcoNano® self-cleaning coating
Max 3150mm width	

Free instant quotes

www.balconette.co.uk

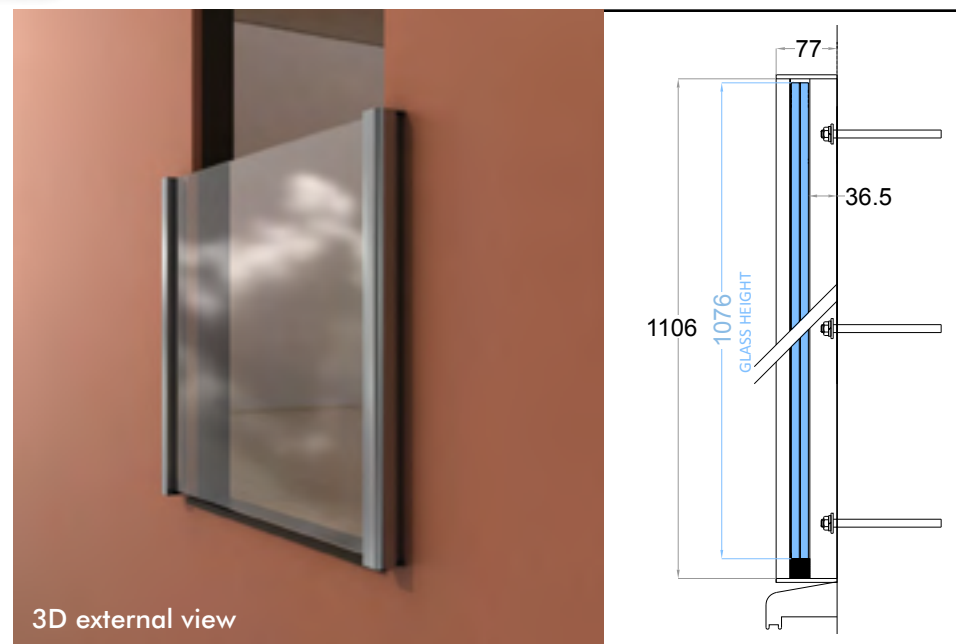

Balcony 1 Balustrade System

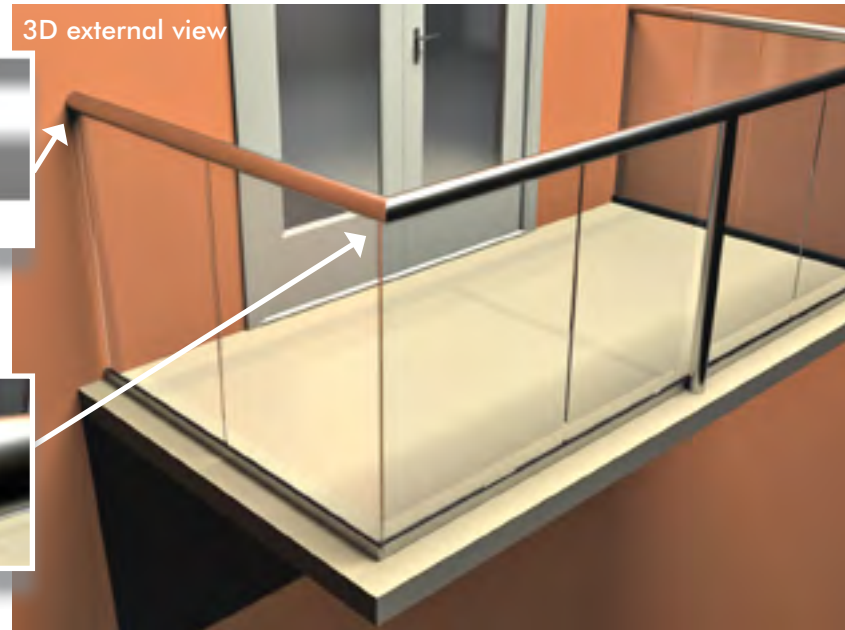
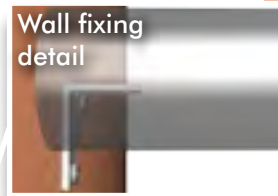

Section

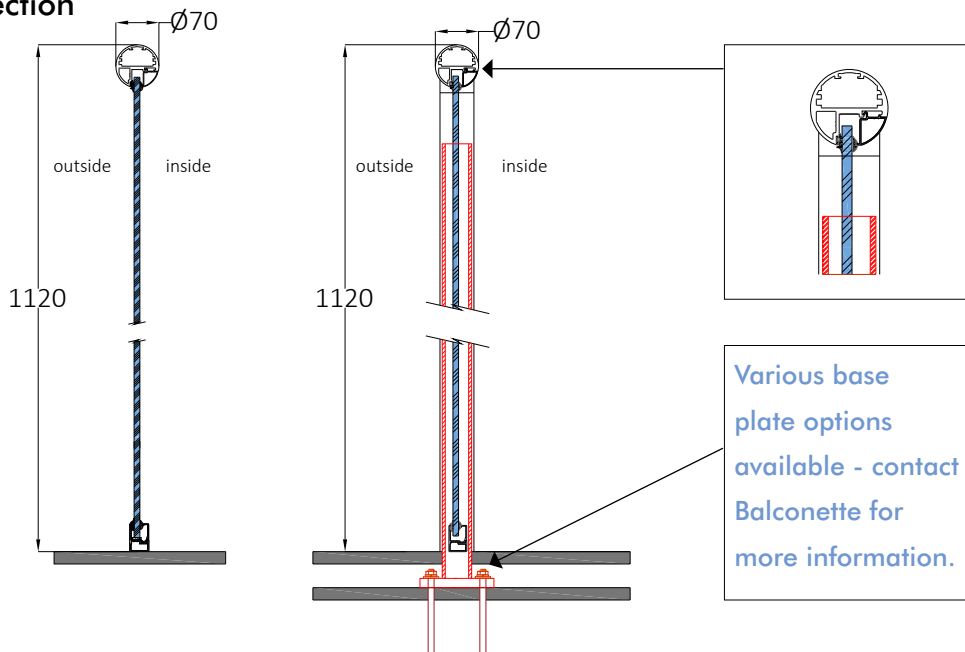

Parameters

Max structural length without posts 3300mm
 Max post spacing 1900mm

Glass options

- 10mm clear toughened
- 10mm green toughened
- 10mm grey toughened
- 10mm bronze toughened
- 10mm blue toughened
- 10mm satin (opaque) toughened

Optional extras (for all glass types)

BalcoNano® self-cleaning coating
 Laminated glass options available

Colour options



Free instant quotes
www.balconette.co.uk



Balcony 1 Balustrade System with 72mm x 72mm posts



Section

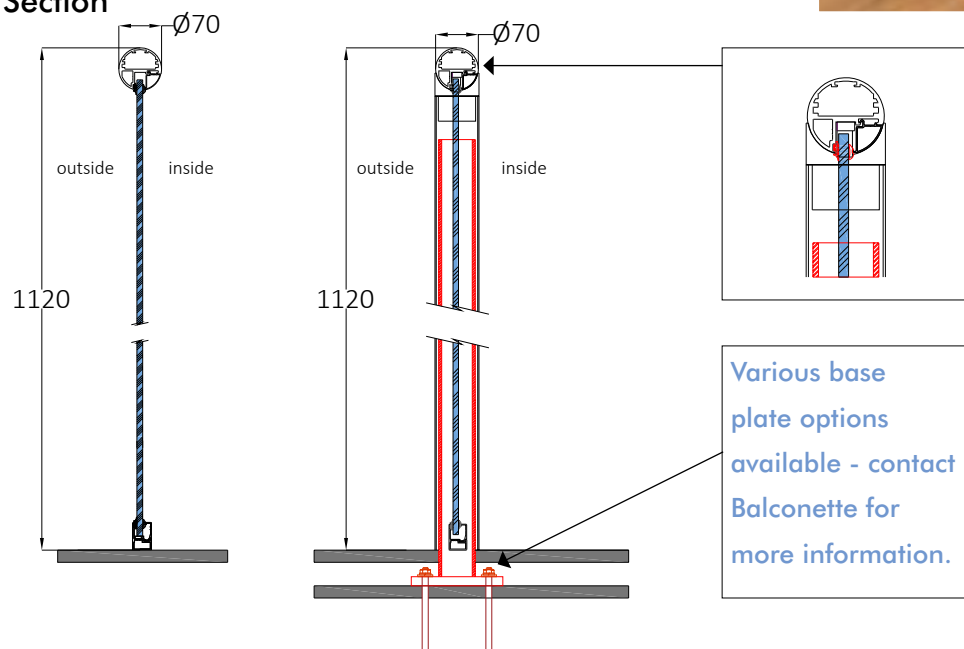

Colour options

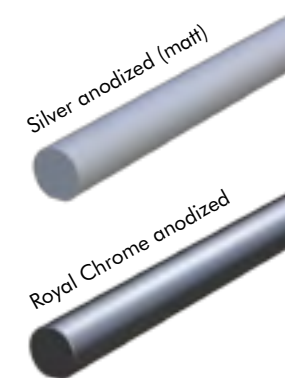

Parameters

Max structural length without posts 3300mm
Max post spacing 2700mm

Glass options

10mm clear toughened
10mm green toughened
10mm grey toughened
10mm bronze toughened
10mm blue toughened
10mm satin (opaque) toughened

Optional extras (for all glass types)

BalcoNano® self-cleaning coating
Laminated glass options available

www.balconette.co.uk



Balcony 2 Balustrade System

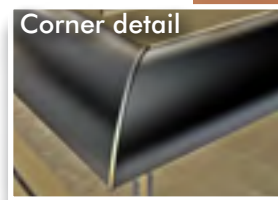
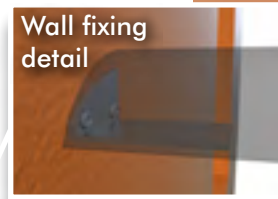

Section

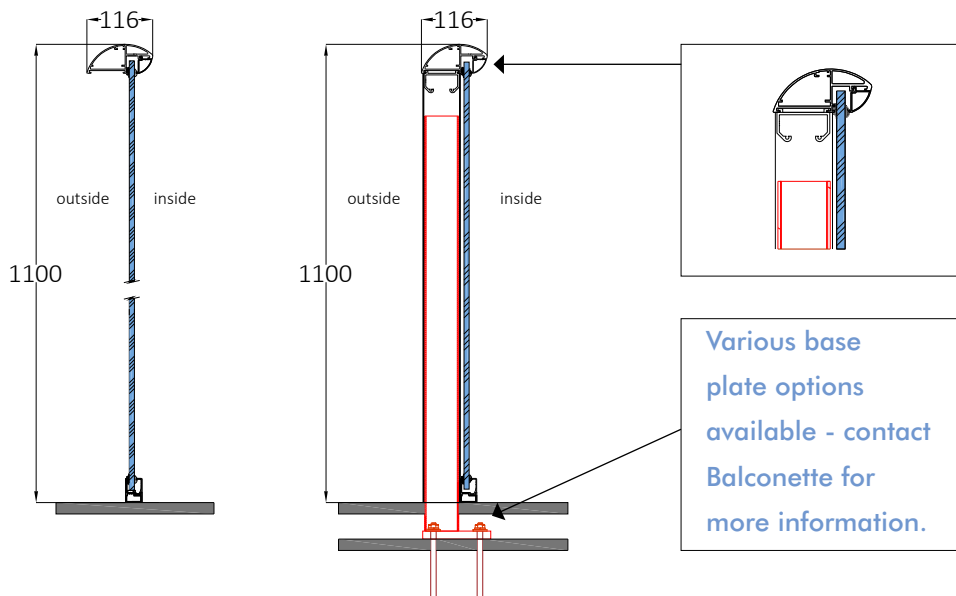

Parameters
Max structural length without posts 4000mm
Max post spacing 2100mm
Glass options
10mm clear toughened
10mm green toughened
10mm grey toughened
10mm bronze toughened
10mm blue toughened
10mm satin (opaque) toughened
Optional extras (for all glass types)
BalcoNano® self-cleaning coating
Laminated glass options available

Colour options



Free instant quotes
www.balconette.co.uk



Balcony 2 Infinity Screen System

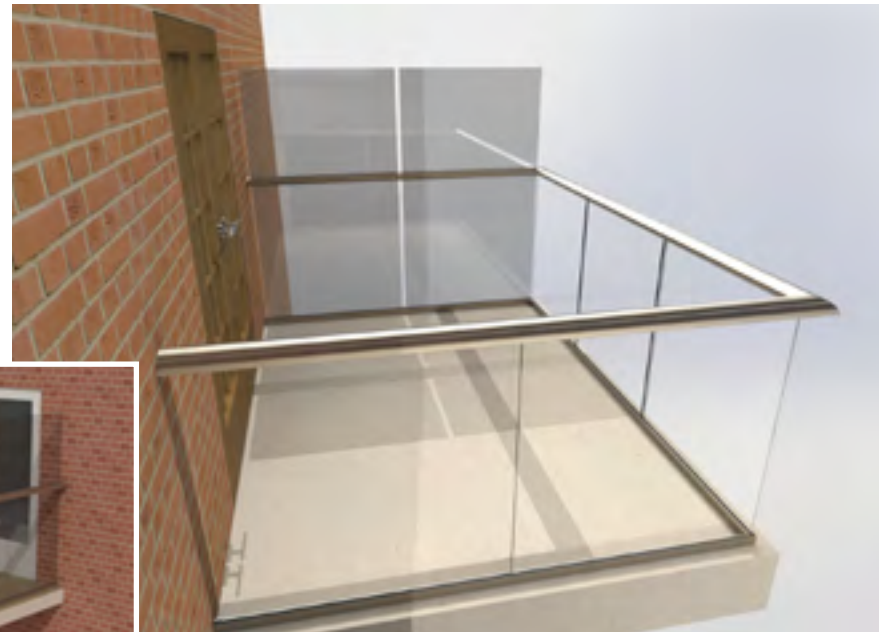

Section

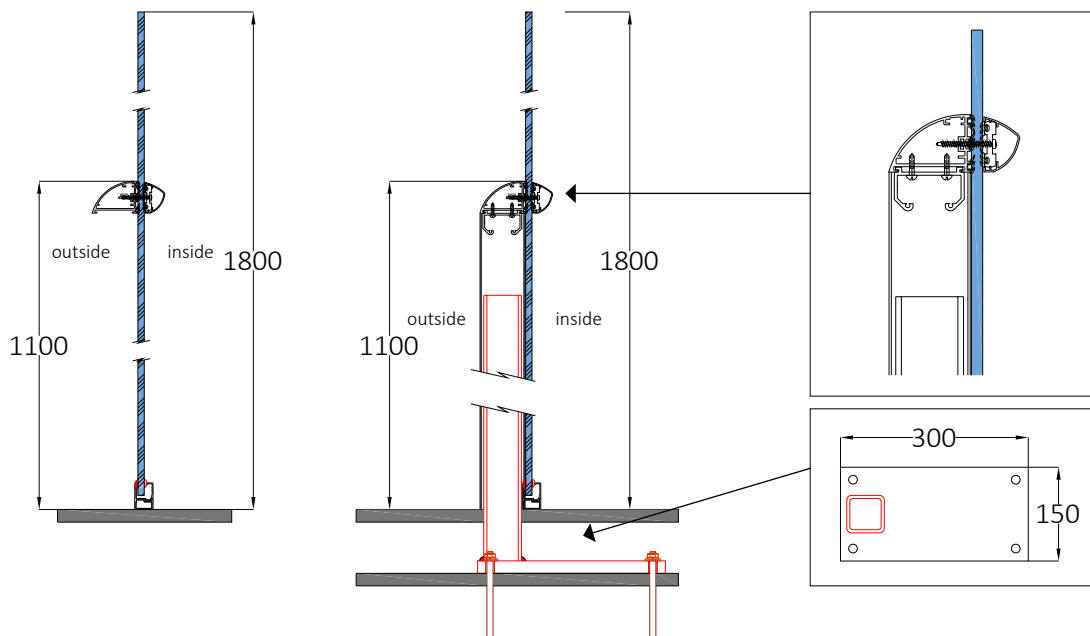

Colour options

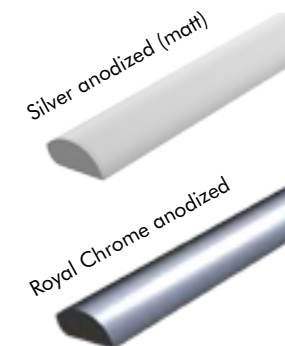

Parameters

- Max height 1800mm
- Max length 2250mm (without posts)
- Max length 1500mm (with posts)

Glass options

- 10mm clear toughened
- 10mm green toughened
- 10mm grey toughened
- 10mm bronze toughened
- 10mm blue toughened
- 10mm satin (opaque) toughened

Optional extras (for all glass types)

- BalcoNano® self-cleaning coating
- Laminated glass options available

www.balconette.co.uk



Balcony 1 Privacy Screen

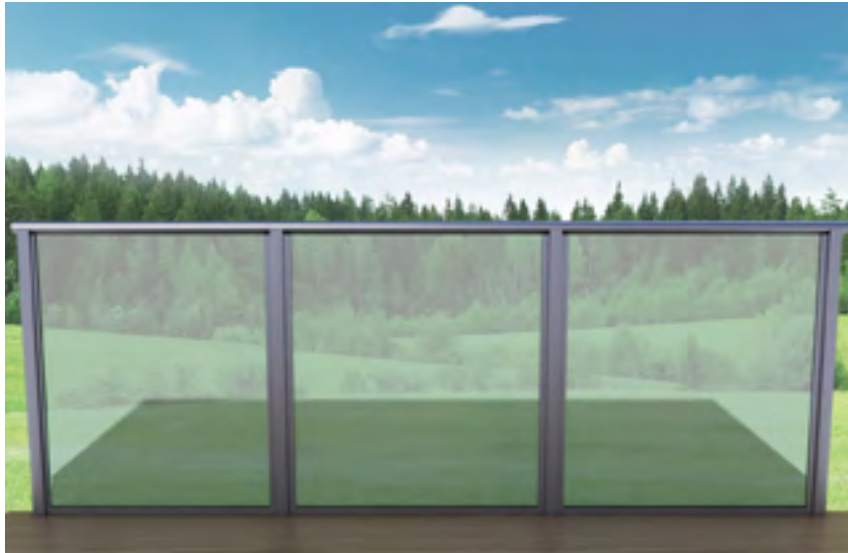

Section

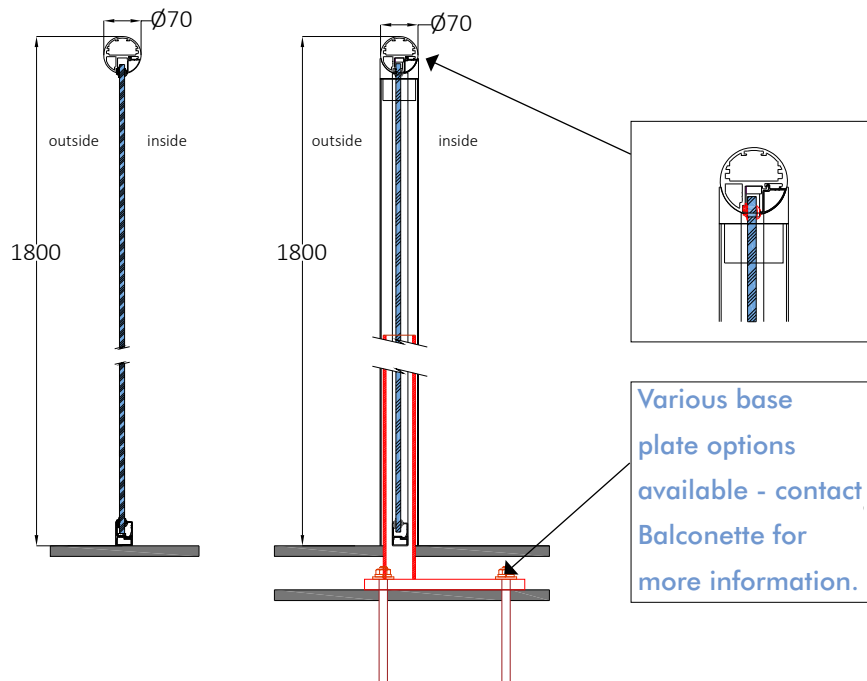

Colour options

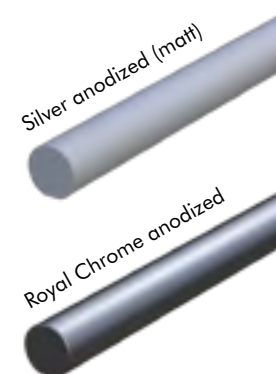

Parameters

Max height 1800mm
 Max length 5400mm
 Post spacing 1000mm/1250mm/1500mm

Glass options

10mm clear toughened
 10mm green toughened
 10mm grey toughened
 10mm bronze toughened
 10mm blue toughened
 10mm satin (opaque) toughened

Optional extras (for all glass types)

BalcoNano® self-cleaning coating
 Laminated glass options available



SG10 Semi Frameless System

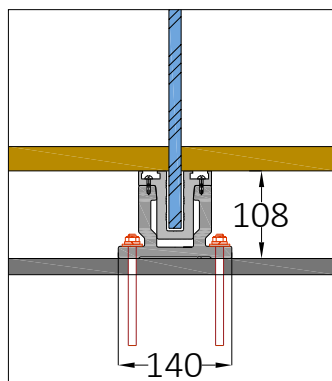
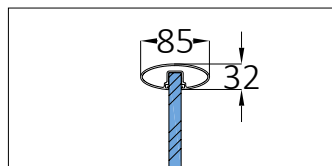
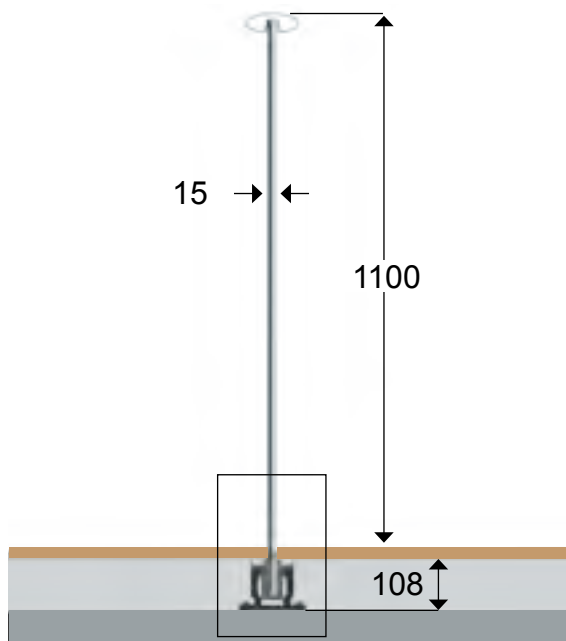
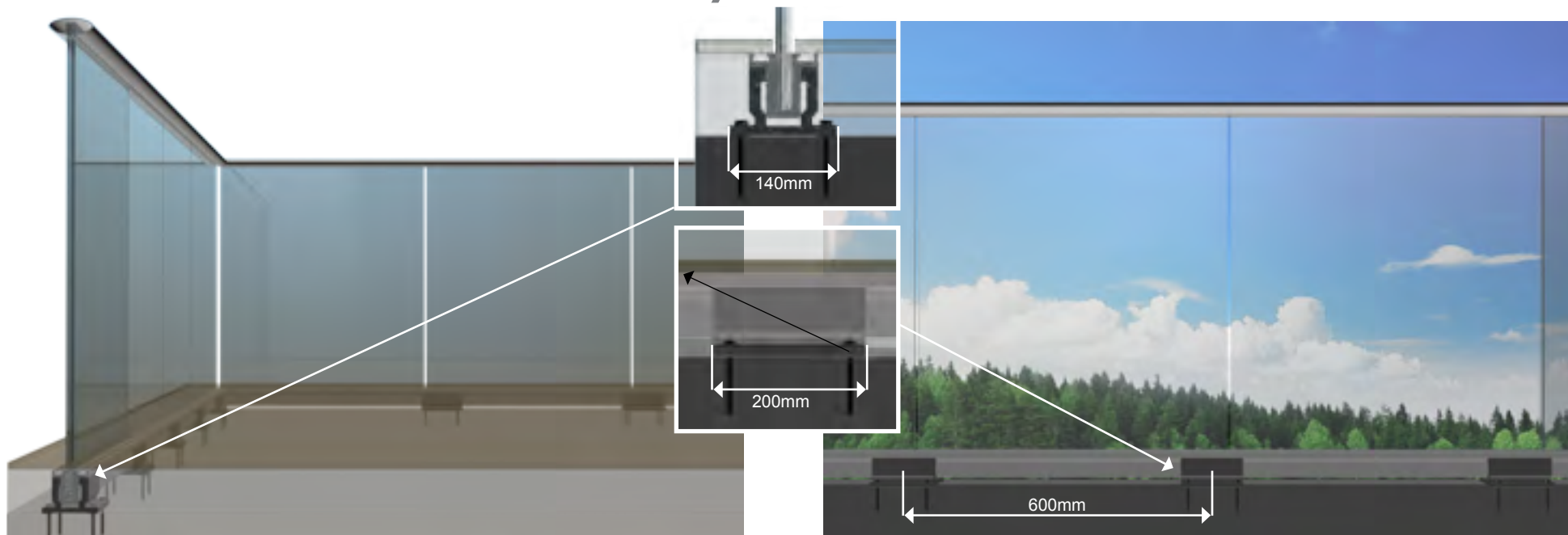

Continuous Glazing Channel

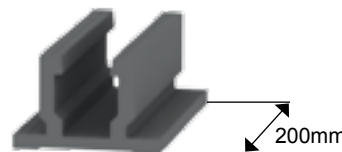

Base Fixing every 600mm

Parameters

Max structural length without posts: unlimited

Handrail colour options

Royal Chrome anodised

Glass options

15mm clear toughened

15mm satin (opaque) toughened

Optional extras

BalcoNano® self-cleaning coating

Laminated glass options available

Free instant quotes

www.balconette.co.uk



SG10 Fully Frameless System

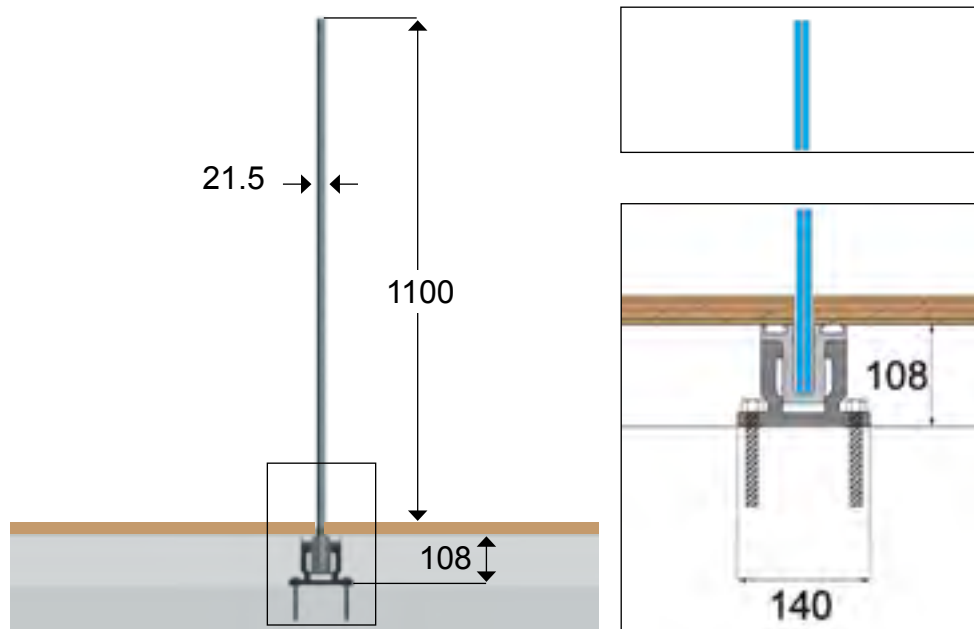
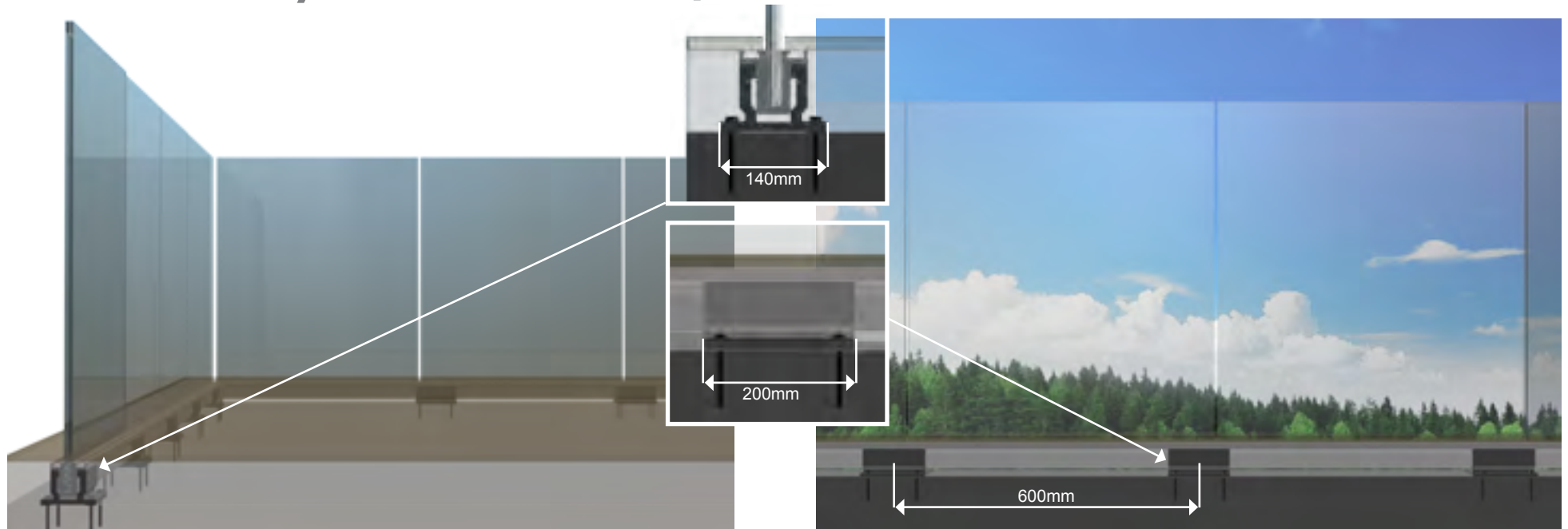

Continuous Glazing Channel

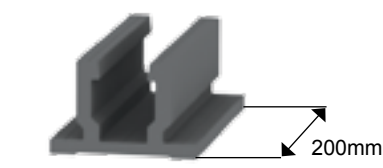

Base Fixing every 600mm

Parameters	
Max structural length without posts:	unlimited
Glass options	
21.5mm clear toughened	
21.5mm satin (opaque) toughened	
Optional extras	
BalcoNano® self-cleaning coating	

Free instant quotes
www.balconette.co.uk



Curved Door Model W2F (2 doors - 1 sliding, 1 fixed)

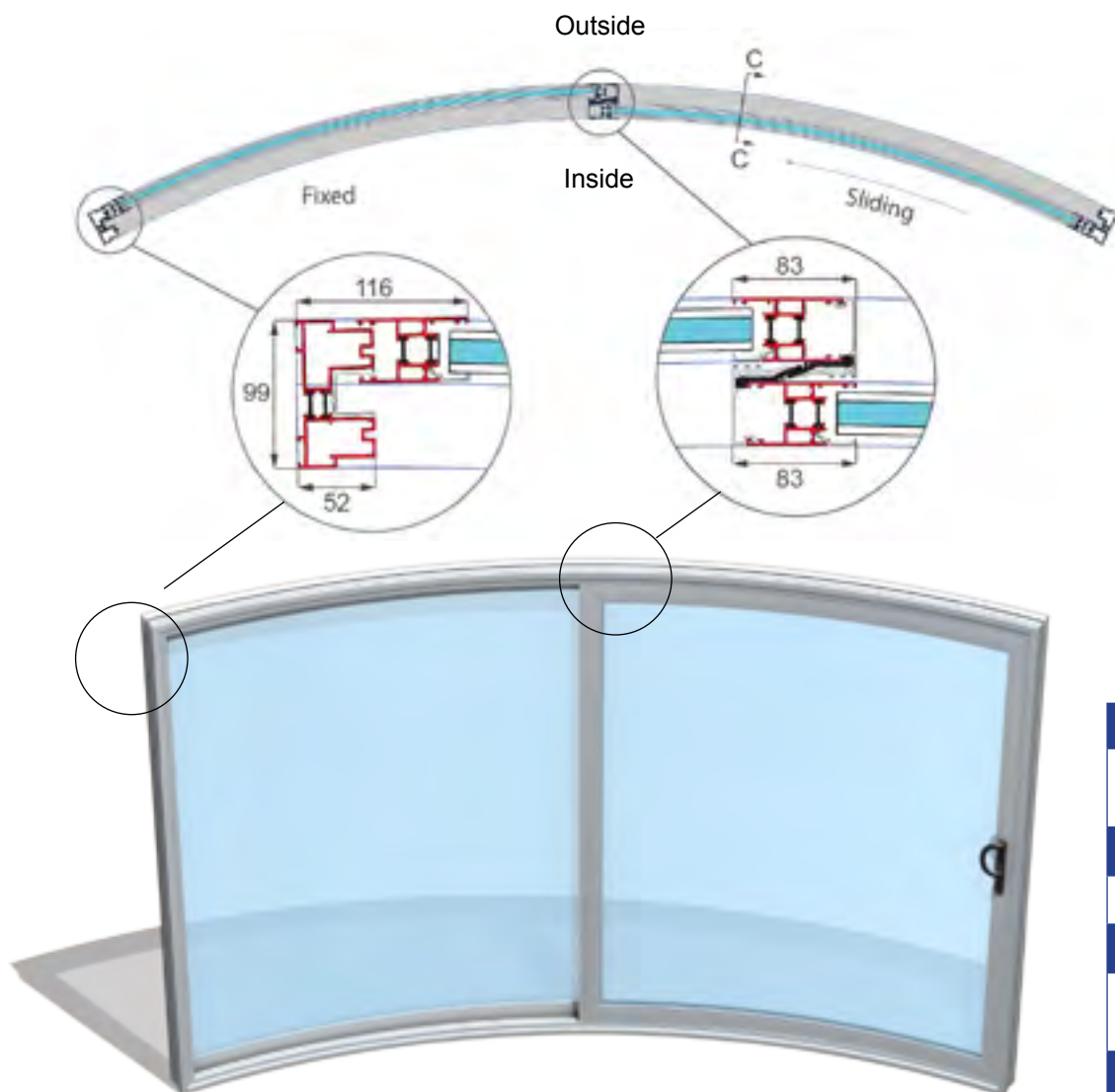

W2F Generic Section C-C

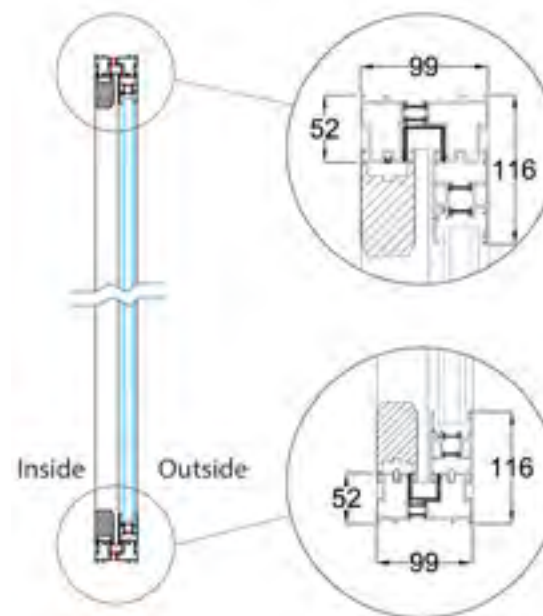

Section profile structure

Twin Polyamide Thermally Broken 6063 T5 extruded aluminium profiles, stainless steel wheel track

Paint/coating: 60-100 micron

Polyester powder coating in standard RAL colour, dual colour options available

Glazing

28 mm Toughened Low-E Double glazing in three options of centre pane U value; 1.7 W/m²K, 1.5 W/m²K or 1.0 W/m²K

Gaskets

EPDM(ethylene-propylene rubber) in black

Recommended max height

2600mm

Recommended max length

3500mm (1750mm per sash)

Sliding mechanism

Regular sliding, bottom rollers

Free instant quotes
www.balconette.co.uk



Curved Door Model W3F (3 doors - 2 sliding, 1 fixed)

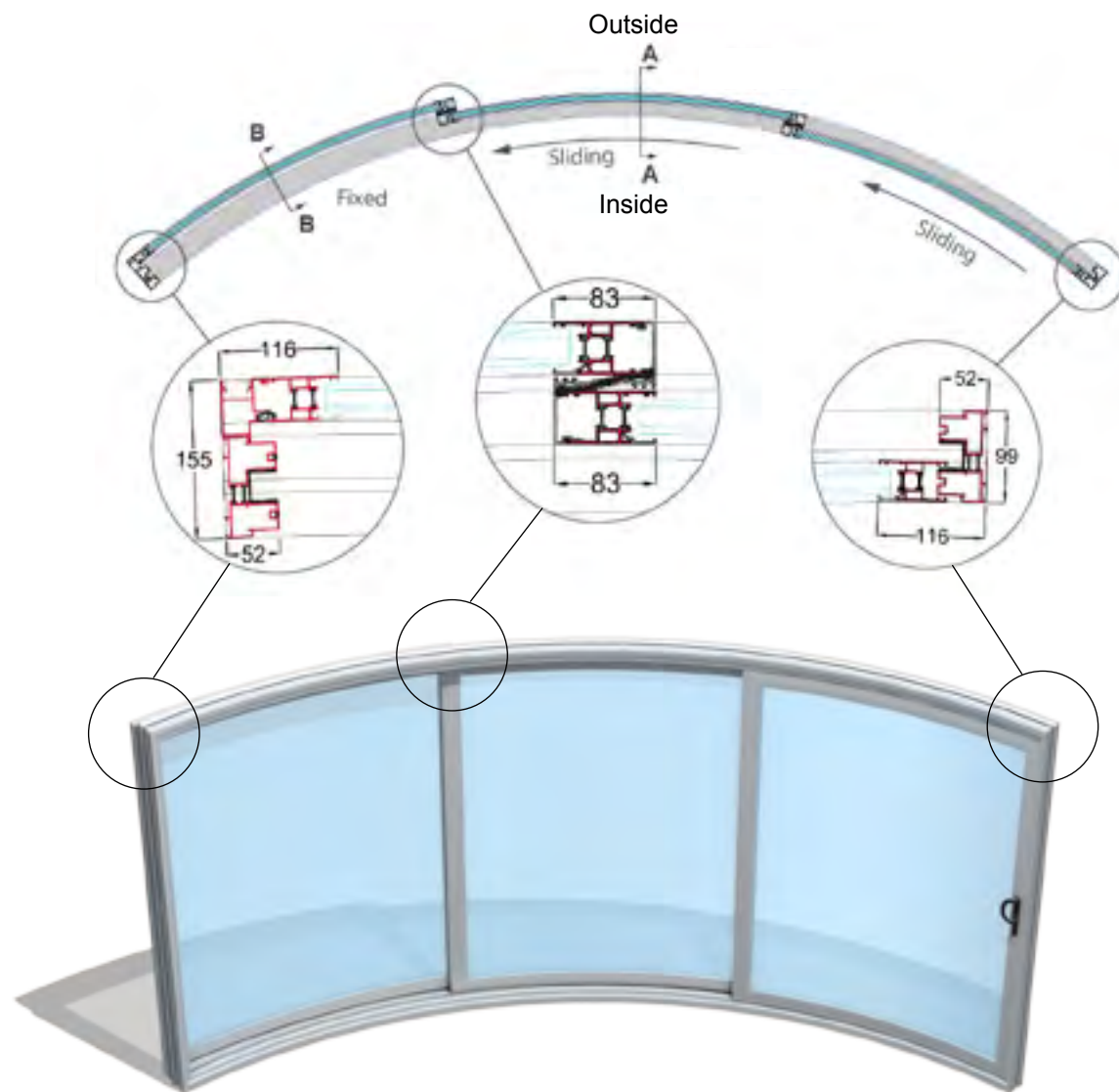

W3F Generic Section B-B

W3F Generic Section A-A

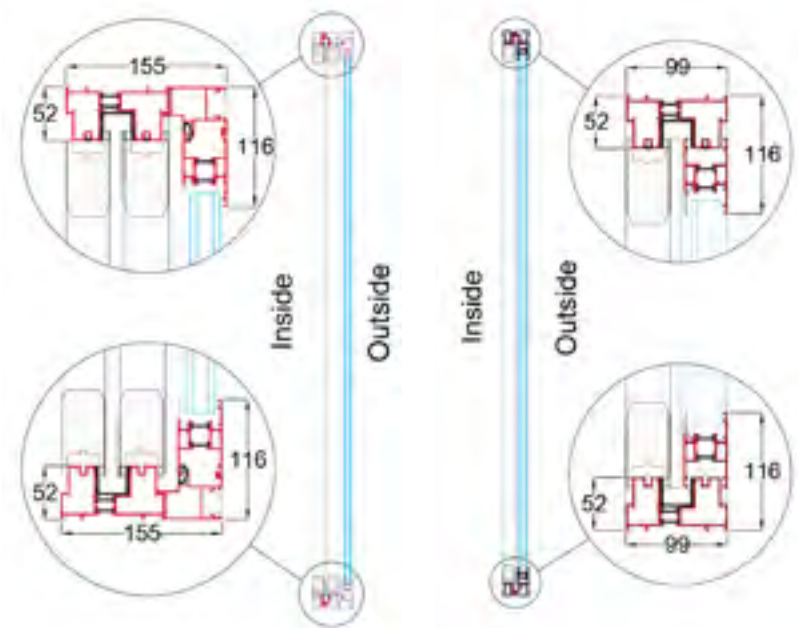

Section profile structure	
Twin Polyamide Thermally Broken 6063 T5 extruded aluminium profiles, stainless steel wheel track	
Paint/coating: 60-100 micron	
Polyester powder coating in standard RAL colour, dual colour options available	
Glazing	
28 mm Toughened Low-E Double glazing in three options of centre pane U value; 1.7 W/m ² K, 1.5 W/m ² K or 1.0 W/m ² K	
Gaskets	
EPDM (ethylene-propylene rubber) in black	
Recommended max height	2600mm
Recommended max length	5250mm (1750mm per sash)
Sliding mechanism	Regular sliding, bottom rollers

Free instant quotes
www.balconette.co.uk



Curved Door Model W4F (4 doors - 2 sliding, 2 fixed)

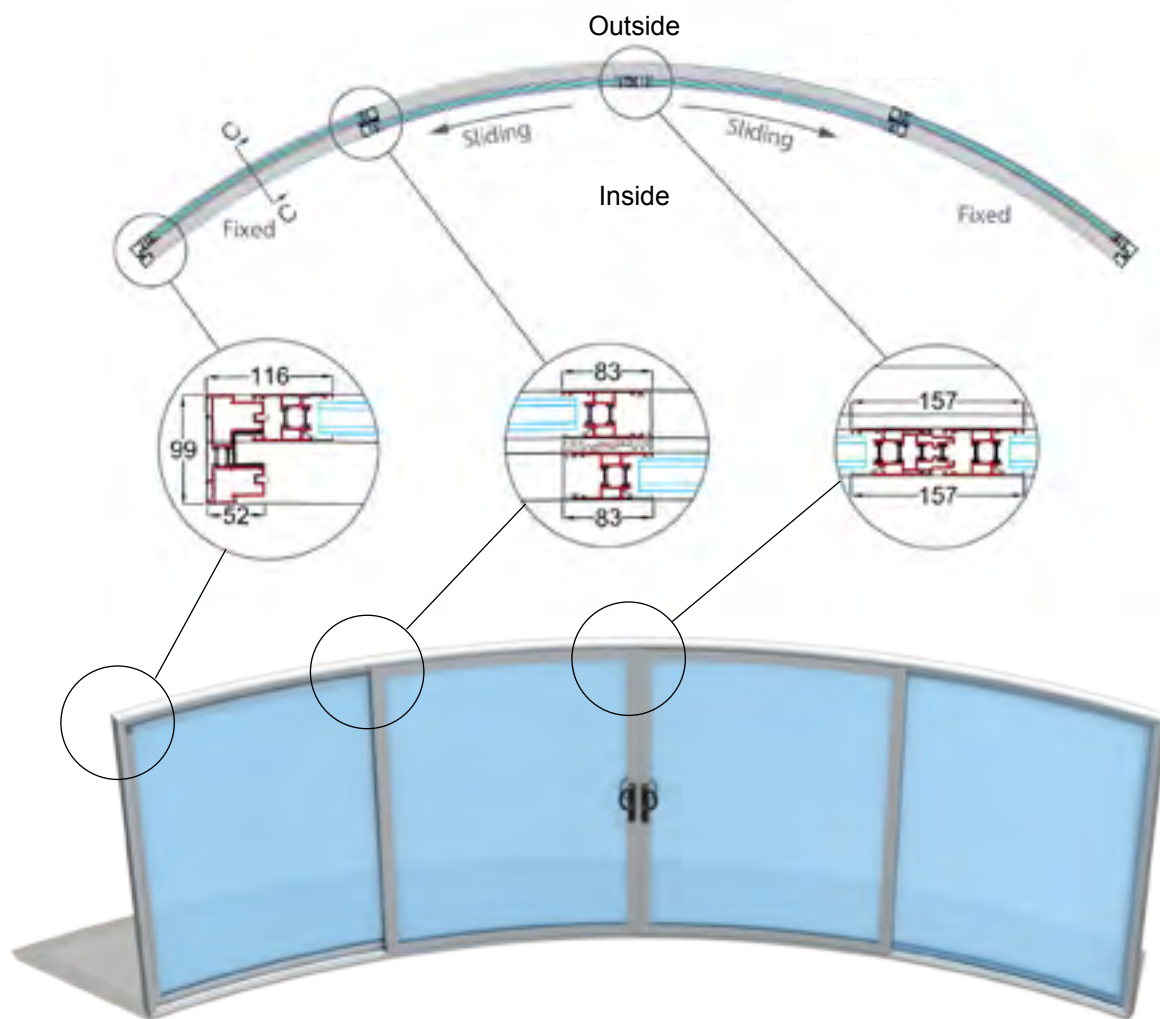

W4F Generic Section C-C

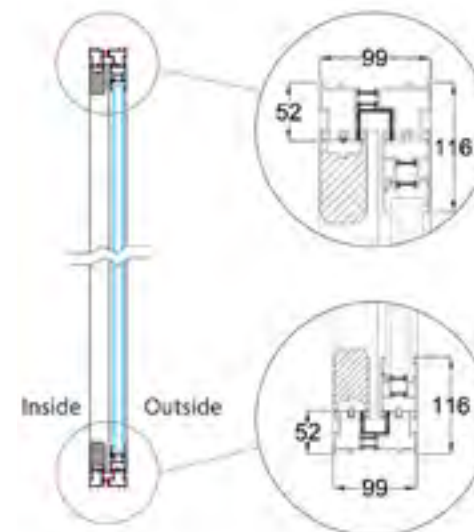

Section profile structure

Twin Polyamide Thermally Broken 6063 T5 extruded aluminium profiles, stainless steel wheel track

Paint/coating: 60-100 micron

Polyester powder coating in standard RAL colour, dual colour options available

Glazing

28 mm Toughened Low-E Double glazing in three options of centre pane U value; 1.7 W/m²K, 1.5 W/m²K or 1.0 W/m²K

Gaskets

EPDM (ethylene-propylene rubber) in black

Recommended max height 2600mm

Recommended max length 7000mm (1750mm per sash)

Sliding mechanism Regular sliding, bottom rollers

Free instant quotes
www.balconette.co.uk



Curved Door Model W6F (6 doors - 4 sliding, 2 fixed)

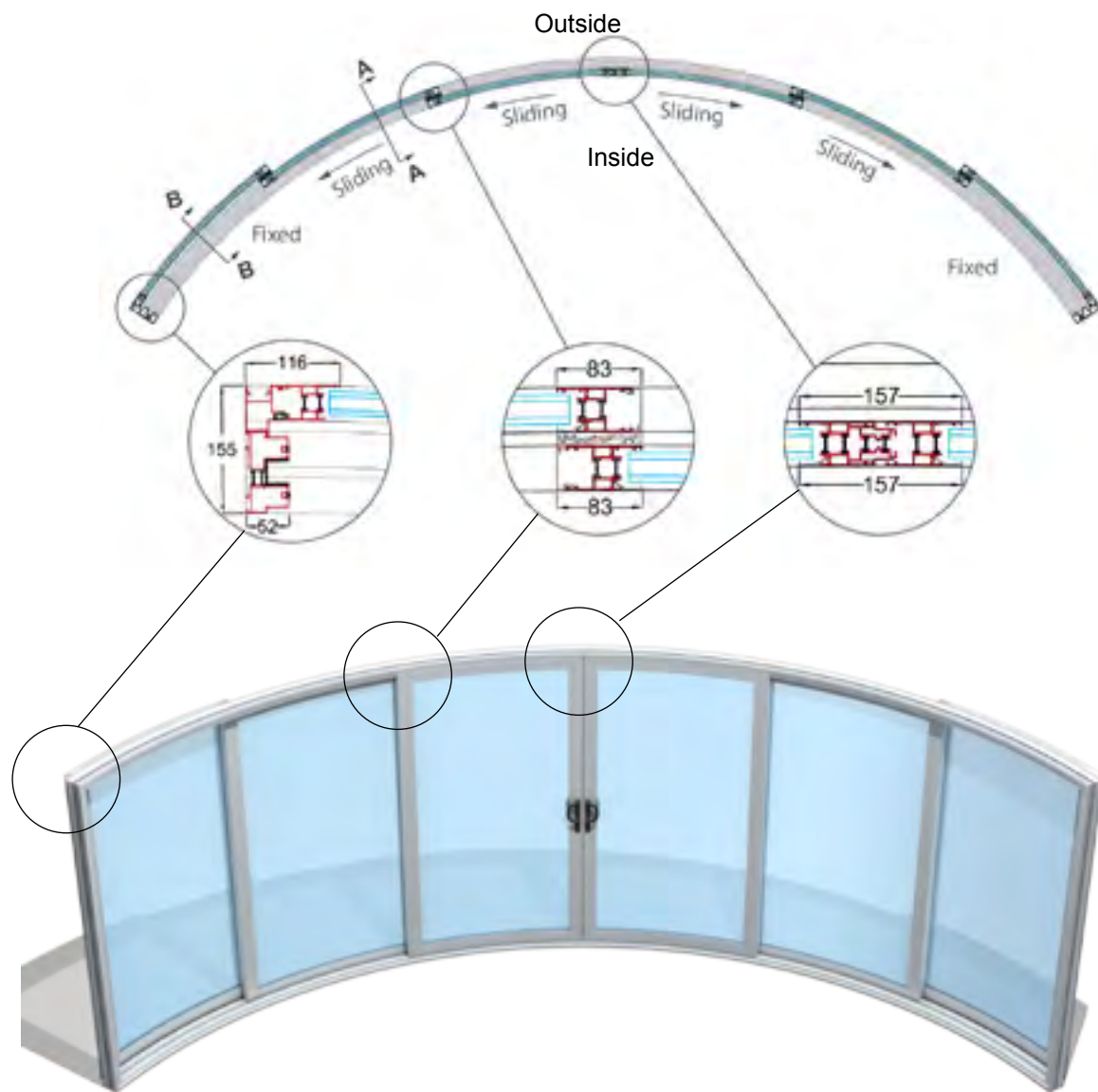

W6F Generic Section B-B

W6F Generic Section A-A

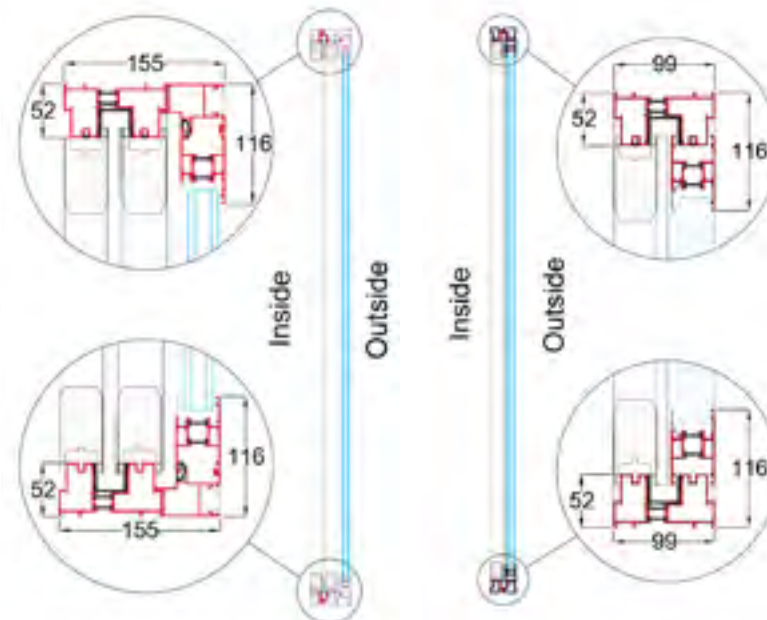

Section profile structure

Twin Polyamide Thermally Broken 6063 T5 extruded aluminium profiles, stainless steel wheel track

Paint/coating: 60-100 micron

Polyester powder coating in standard RAL colour, dual colour options available

Glazing

28 mm Toughened Low-E Double glazing in three options of centre pane U value; 1.7 W/m²K, 1.5 W/m²K or 1.0 W/m²K

Gaskets

EPDM (ethylene-propylene rubber) in black

Recommended max height 2600mm

Recommended max length 10500mm (1750mm per sash)

Sliding mechanism Regular sliding, bottom rollers

Free instant quotes
www.balconette.co.uk



BalcoNano® Advanced Glass Coating

DIY Self-Cleaning Glass Sachets

An easy-to-use self-cleaning glass coating application

This unique coating has only been available in a factory applied version until now.

You can now apply the BalcoNano® coating yourself in an easy to use sachet application.

The double sachet contains a ready to use "wet wipe" towelette that is pre-soaked with the BalcoNano® coating and the BalcoNano® cleaner ready to use directly to the surface you wish to coat.

Balconette have launched a revolutionary packaging that enables an easy DIY application.

No need for any prior experience of using the product, you can turn your existing ordinary glass into "self-cleaning" glass.



The sachet pack comes as a two part set, one sachet with the BalcoNano® glass cleaner and the second sachet containing the BalcoNano® coating.

Each sachet pack is suitable for coating approximately one square meter, or eleven square feet.

The long term cost savings from applying the coating are tremendous. Coated glass will require 50%-90% less cleaning.

Heavy Duty Glass Cleaner

A strong glass cleaner for lodged dirt, grime and other deposits that cannot be cleaned with regular cleaners

Why is it that some glasses will just not clean no matter how much you scrub?

Our unique formula for heavy duty glass cleaning will release some of the really deeply lodged deposits that have accumulated over time.

Some glasses that have severe surface deterioration and corrosion can sometimes be restored using this very strong glass cleaner that will release lodged dirt, grime and other deposits that cannot be cleaned with regular products.

The BalcoNano® heavy duty cleaner is only the first step in restoring the glass.



Once the glass surface is clean from the imbedded contaminants, the BalcoNano® coating must be applied to protect the surface from future contamination.

The BalcoNano® heavy duty glass cleaner can also be used to remove the coating when needed so is not intended for use after coating the glasses.

BalcoNano® Shower Renovation Kit

Tired of irremovable streaks and marks on your shower glass?

The shower renovation kit includes all that you need to restore your shower glass to as new and protect it so it remains this way.

Shower glass is particularly prone to build up of scum, soap, calcium and other grime. A glass screen on a shower will get severely contaminated and dirty within only a few months of use.

The kit includes a 500ml bottle of the BalcoNano® heavy duty cleaner to be used in the first stage. This will remove the deep lodged dirt and particles.

After cleaning use the 10 double sachets of the BalcoNano® coating to protect the glass surface from future contamination.

The kit also includes a premium microfiber glass cloth which is perfect for removing heavier soilings from all hard surfaces. The micro fibres work through capillary action, drawing dirt into the cloth.

Also included is a pair of powder free blue nitrile gloves – the gloves provide superior resistance to chemicals,

cuts, tears and abrasions with a soft, conforming design whilst offering great levels of dexterity and sensitivity.

The kit contains:

- 1 x 500ml bottle BalcoNano® heavy duty cleaner
- 10 x BalcoNano® double sachet packs
- 1 x premium microfiber glass cloth
- 1 x pair of powder free blue nitrile gloves



www.balconano.com



Glass corrosion – can anything be done?

Glass quietly gets on with doing a fantastic job in our lives. It secures and lets light into our buildings, while also protecting us from the elements. Yet while every other component of a building, such as steel, aluminium, timber and concrete, has surface protection, glass is simply left bare and vulnerable to corrosion, contamination and degradation over time.

Build-up of grime and salt deposits, if not removed, can attack the transparent surface of glass turning it opaque. So why don't we do more to look after this often-neglected material which is essential for our well-being, when protective solutions are readily available?

“Build-up of grime and salt deposits, if not removed, can attack the transparent surface of glass turning it opaque.”

Have you ever experienced glass stains or streaks on glass that, no matter how hard you try to clean them, just will not budge? Why do shower enclosures get dirtier and

more opaque over time? Why does it seem impossible to remove finger prints from sandblasted glass?

Although glass may seem to have a smooth surface, the microscopic

surface topography of glass is actually uneven and pitted with peaks and valleys. This surface architecture is the hidden reason behind many glass-related problems.

To understand this problem we need to zoom into the surface of glass.

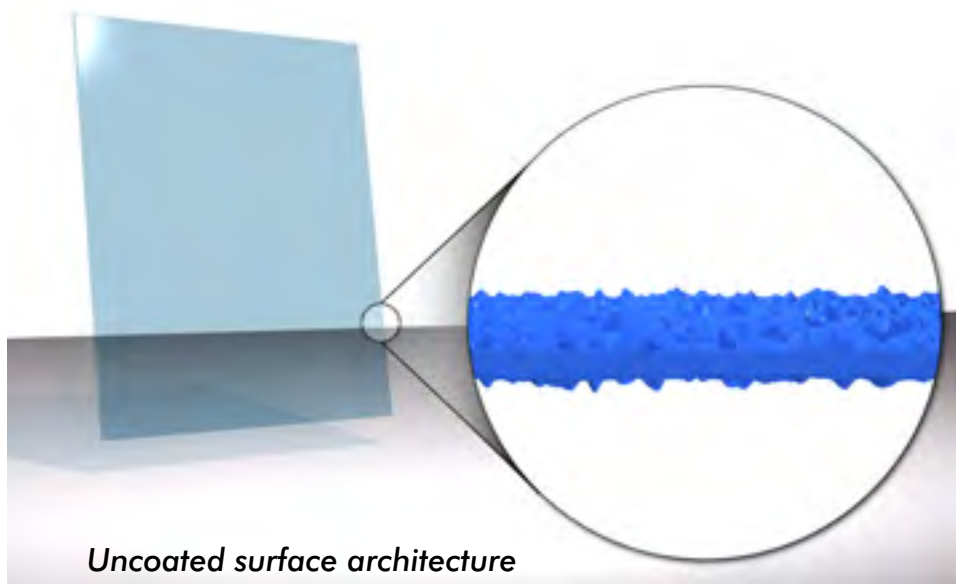

Uncoated surface architecture

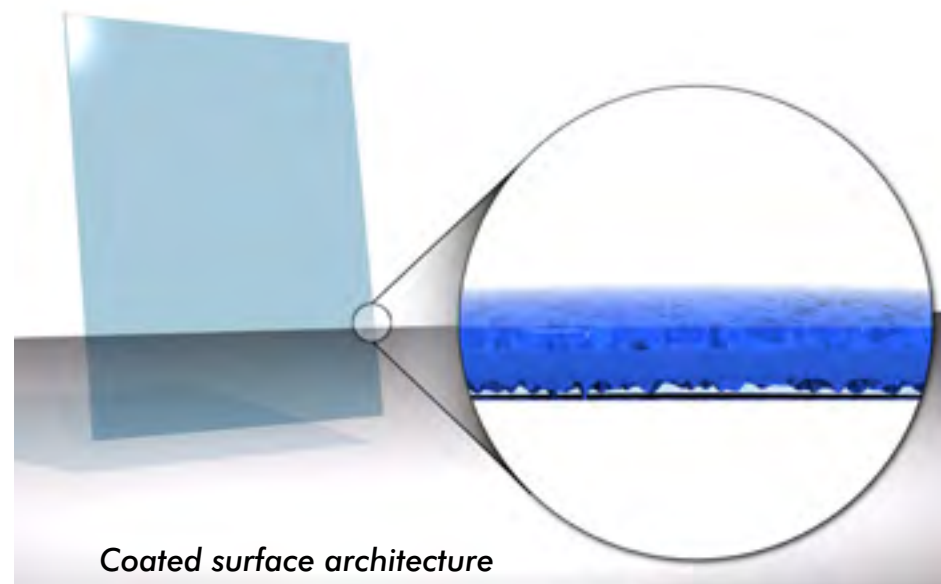

Coated surface architecture

Glass surfaces naturally attract water (hydrophilic), meaning that when water makes contact with the surface of glass the water will tend to spread out and form a thin sheet on the surface. When the water evaporates, all the mineral deposits it contained are left on the surface of the glass. These deposits, which include calcium, salt, heavy metals and a wide range of minerals, together with dust, grime, bacteria, soap scum and a long list of contaminants, embed themselves into the pits and valleys inside the surface of the glass.

These elements get lodged, building up over time, slowly making the glass surface more and more opaque, dirtier and harder to clean.

This phenomenon is amplified on glasses such as etched or sandblasted. This is because etching or sandblasting will make the surface even coarser, rougher and more prone to this problem than regular glass.

Anyone who has handled sandblasted glass will tell you that removing finger prints or dirt from this type of glass is a real nightmare.

Nature – showing us the way

It is curious how we find in nature some of the most advanced technologies that only in the last few years we, mankind, have been able to partially copy or imitate.

Some plants and creatures have created a brilliant way of staying clean. For example, we have the lotus leaf that possesses a very unique surface architecture; this architecture makes the surface of the leaf super-hydrophobic, which means super-water-repellent. Water that comes into contact with the leaf, curls up almost into a ball, leaving an absolute minimum amount of contact with the leaf's surface. Not being able to cling to the surface of the leaf, the water droplets will cling onto anything else on the surface, namely any dirt or dust. This dirt and dust on the leaf's surface gets washed off by these droplets leaving the leaf clean.

The lotus effect

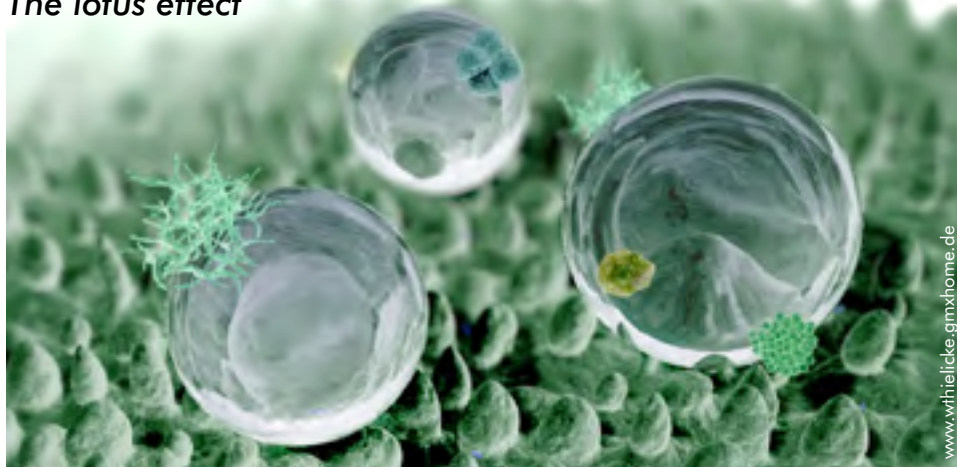

www.vthiellcke.gmxhome.de

The solution – BalcoNano® advanced glass protection

Inspired by the lotus leaf's self-cleaning technology, we have created a unique and very durable coating for glass that actually transforms the surface architecture of glass, turning it from a hydrophilic (water-attracting) into a hydrophobic (water-repelling) surface.



How BalcoNano® advanced glass protection works

At only 20 nm (nanometre) thick, BalcoNano® works at the nano-scale level – a nanometre is one billionth of a metre or one millionth of a millimetre (1 millimetre = 1,000,000 nanometres).

The BalcoNano® coating forms a hard, clear and super-smooth surface on the glass, covering entirely these problematic pits, peaks and valleys of the underlying glass surface. It transforms the surface into one that is charged and water-repellent. Water

that now comes into contact with the coated glass will not have access to the pits and valleys; water will sit high on the surface and the droplets will tend to curl up and quickly roll away.

Dirt, grime, calcium and other deposits will not be able to embed themselves into the surface and will wash away easily. Teflon is a good comparison. Just as Teflon protects the underlying metal on a frying pan, so BalcoNano® protects the underlying glass surface.

“Eco-friendly & pocket-friendly, BalcoNano® eliminates the need for harsh chemical cleaners.”

“Completely transparent ensuring your enjoyment of the glass is not limited in any way.”



BalcoNano® is factory-applied shortly after the glass processing is complete. The glasses are deep-cleaned and then put into an enclosed chamber where they are exposed for a few hours to a series of vapours that form the unique BalcoNano® surface.

The chamber application has an added benefit in that the BalcoNano® surface coating is created simultaneously on both faces of the glass, protecting the glass on the inside and outside at the same time.

Completely different to any manual application, the chamber system is an ultra-efficient method that allows us to process large amounts of glass in every chamber cycle. The process is closely monitored by a computer that constantly

checks temperature, humidity and air flow so the resulting coating can be replicated exactly every time.

Using this method we can apply the BalcoNano® coating to the glass on our balustrades, glass Juliet balconies and curved glass double glazed units.

Benefits of the BalcoNano® coating:

What are the benefits of the BalcoNano® coating? And is it worth the extra cost?

Here are some of the benefits:

- Protects the glass from lodging of dirt, grime and other contaminants
- Forms a hard water-repellent surface on the glass

- Reduces required frequency of cleaning between 50% and 90%
- Eco-friendly & pocket-friendly - eliminates the need for harsh chemical cleaners
- Increases impact & scratch-resistance
- Makes the glass surface graffiti-proof
- Keeps glass looking NEW for longer
- Completely transparent ensuring your enjoyment of the glass is not limited in any way

Can the BalcoNano® coating be applied to existing glasses?

As customers began to recognise the immense benefits of the BalcoNano® self-cleaning glass coating, demand quickly followed for an on-site application for other glass products and elements so these too can enjoy the protective assets of the coating.

Balconette rose to the challenge and created a “DIY self-application” pack for on-site application of the BalcoNano® coating.

BalcoNano® can now be applied to glass that is already installed using the sachets system. Each sachet pack contains the required two-part system, a special glass cleaner and the BalcoNano® coating. Each sachet contains a pre-soaked towelette ready for immediate use.

The sachets are designed to be used by the homeowner or professionals alike, enabling the unique coating to be applied to existing glass in doors and windows, conservatories, shower enclosures and much more.

The coating chemistry works just as well on other silica-based products such as ceramics, porcelain, marble and stone. This means the sachets can be used to apply the coating to kitchen tops, sinks, ceramic tiles and many other areas.



Customer feedback on the BalcoNano® coating

Here are some testimonials from customers who have ordered the BalcoNano® coating for their balustrades, Juliet balconies and other glass products.

Graham Spencer of London, said:
"Having used the coating on a shower cubicle, I can say it helps to keep the glass cleaner. Overall, I would say it's better to have it on than not."

Anne Edwards of Devon, said:
"I have noticed a difference on a couple of hard-to-reach Velux windows. They do stay cleaner and I am pleased with the product. I will be using it on more windows other than the Velux ones."

Rachel Brickley of Battersea, London, said: *"The coating has worked really well on the full-length mirrors in my shower. I've definitely noticed a difference and it has reduced the cleaning a lot. Definitely recommended!"*

Craig Williams, Managing Director, Blind and Track Service Ltd, Salisbury, said: *"I have used the BalcoNano® coating on two glass conservatory roofs and the feedback from the clients has been very good. It is working really well for them and they say the roof stays cleaner than it did before."*

William Davies of Milton Keynes said: *"We purchased the coating for high-access Velux windows in one of our rental properties to reduce maintenance. As the windows are difficult to access and clean, we think it's a good idea to use a product that will keep the glass cleaner for longer."*

Mildred Hindle of Preston said:
"I applied it to my shower screen and it's very good. I'm very impressed with it. It's an excellent product. In fact I've recommended it to several people. The coating makes everything easier to clean without a shadow of a doubt. You can see it working and it's so simple to just rinse the glass with the handheld shower afterwards."

Summary

As architects, developers, homeowners and self-builders become more knowledgeable and understand the reasons behind glass dirt retention the need becomes apparent for a cost-effective and durable solution.

The BalcoNano® glass coating presents an eco-friendly and durable solution that literally pays for itself, both in saved cleaning frequency and time, plus in eliminating the need for use of expensive chemical cleaners.



"The BalcoNano® glass coating presents an eco-friendly and durable solution that literally pays for itself."

Balconette's balustrade and composite decking add 'wow factor' to Reigate home

A smart new glass balcony and composite decking, both supplied by Balconette, add the perfect – and practical - finishing touch to a basement extension in Reigate, Surrey.

Having specified Balconette's BalcoNano® self-cleaning glass coating on both sides of the balustrade panels that reduces the need for cleaning, Paul and Alison Swain are finding that the structure is also very low-maintenance.

The protective coating creates a smooth, water-repellent surface so dirt and other deposits cannot cling and are easily washed off by rain or wiping with a wet cloth; an ideal choice for an outdoor glass balustrade.

Nearly two years after it was first installed, Paul says the balustrade's coating is performing well. "It doesn't need a lot of cleaning, two or three times a year is enough to keep it looking sparkling and it's easy to do," he comments.

"Despite the recent very wet winter weather, we haven't had to wash it for a long time. Generally speaking, once it's dry we don't get drip stains on it. So in our opinion, we think the coating has helped."

The couple created an extra 57m² of useful living space by enlarging an existing basement at their 1930s home. The extension houses a new family room, study/spare bedroom with shower and a utility room.

Accessed via bi-folding doors from the kitchen/diner, the new South West facing terrace and balustrade sits on the roof of the new accommodation, providing valuable extra outdoor space from which to enjoy garden views. An older deck on stilts was demolished as part of the works.

Delighted with the result, Paul says they're pleased they chose glass over the original wooden spindles specification for the balustrade, which measures just over 20 metres including a stair balustrade leading to the adjacent driveway.

"When we look at the glass balcony, we get an unobstructed view across the garden. Our Balconette balustrade just 'melts away'; you're not really aware it's there. Other types, such as those with clamps to hold the glass, just don't compare to this," said Paul, who works in destination and event management marketing.

The new decking, in a mellow Coppered Oak finish, is made from a unique polyurethane and mineral blend providing long-lasting durability with a slip-resistant surface and minimal maintenance. It is complemented with the Balcony 2 balustrading system using the aerofoil-shaped handrail in Balconette's proprietary Royal Chrome anodised finish.



"It doesn't need a lot of cleaning, two or three times a year is enough to keep it looking sparkling and it's easy to do"

Having heard about Balconette from Grand Designs Live, the couple visited their Lingfield showroom to view the products first-hand, after which they obtained a quote.

They were put in touch with Peter Leck and Simon Ritchie's Tunbridge Wells construction company, one of Balconette's Approved Installers around the UK, who installed the balustrade and decking system.

"After seeing Balconette's products and how they can transform properties, our minds were made up," continues Paul. "Peter and Simon did a fantastic job and paid great attention to detail and getting the measurements spot on."

For Peter, the main challenge was building a deck on top of the extension that wasn't completely square. He explains: "By building the deck sub-frame and balustrade square, we were able to correct all the issues and these now work together. Stopping the balustrade short of the edge has also created an 'outer walkway' to facilitate easier cleaning of the glass.

Paul adds: "Both the balustrade and decking deliver the 'wow factor' for us. We use the deck all the time and it looks lovely. It's what we wanted and I'm glad we didn't scrimp on the balustrading; it was well worth the extra expense!"

Balconette's Composite Decking

Balconette's Composite Decking is a new generation of external flooring that perfectly complements Balconette's existing product portfolio.

This innovative decking solution is made from a unique polyurethane and mineral blend providing long-lasting durability with minimal maintenance.

The composite decking is very low-maintenance as it does not absorb or give off moisture or swell and shrink like wood. It is also coated in a UV stable hard wearing polymer, which is a non-porous substance that resists the growth of algae as well as having self-cleaning qualities.

Balconette offers a full decking range including

finishes such as Enhanced Grain (Jarrah, Coppered Oak, Golden Oak, Smoked Oak, Limed Oak), Weathered (Driftwood and Vintage) and Carbonised (Charred and Emberred).

Our decking combats the common drawbacks of solid wood decking:

- Does not rot
- No warping or cracking
- Slip-resistant surface
- Looks like real wood and retains the colour

Why is this different and better?

The durable top layer is anti-abrasive, anti-slip, UV stable, resilient.

Solid, not hollow and no wood content = no algae. The blended polymer resin does not rot, warp or crack.

Highly resistant to scratches and stains.

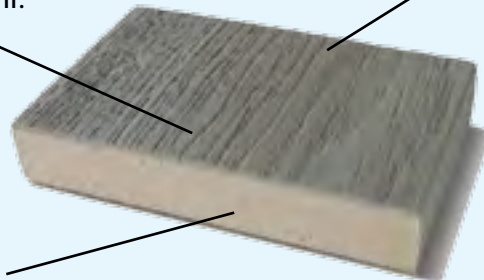

58 Board colours, finishes and options

59 Finishing touches

60 Installation options and features

62 Advantages and specifications of Balconette's Composite Decking

63 Case study: balustrade and decking are perfect partners



Board colours, finishes and options

With a range of different textures and colours to choose from, there's a decking product to suit your individual requirement - adding character and style to your balcony or outdoor space.

Enhanced Grain (smooth, wood-grain finish)

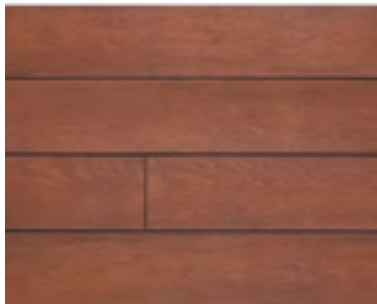

Jarrah



Coppered Oak



Golden Oak



Smoked Oak



Limed Oak

Carbonised (burnt wood finish)

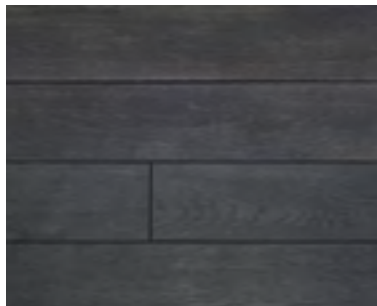

Charred



Emberred

Weathered (aged wood finish)



Driftwood



Vintage



Jarrah

Finishing touches

Decorative fascia boards and step edgings add those all-important finishing touches to your decking project.

Decorative Edging

Available in a Bullnosed, Ribbed or Square design, this edging product is invaluable whenever there is a change of level to provide a seamless finish. Both edgings are available in rigid (standard) and flexible material and are available in the full range of colours.



Limed Oak



Coppered Oak



Golden Oak

Fascias

Decorative fascias are supplied rigid as standard but can also be requested in a flexible style to follow the shape of curved decking. They are also available in a variety of colours, perfectly matching the decking to give a neat and tidy finish to any installation.

“ . . . available in a variety of colours, perfectly matching the decking to give a neat and tidy finish . . . ”

Installation options and features

Fixings

Ghost Fixings – they are there but hardly visible.

Installation is simple as Balconette's stainless steel Ghost Fixings 'lost head' fixings just screw in. The screw is hidden

as the composite decking board 'self-heals' back over itself, leaving virtually no mark for a cleaner finish.

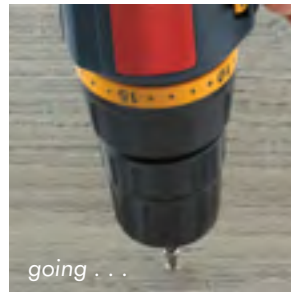
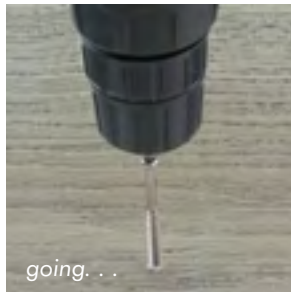

"The screw is hidden as the composite decking board 'self-heals' back over itself..."



Driftwood



Water Resistant Sub Frame

As the ideal partner to complement any of Balconette's decking products, this sub frame solution enables us to offer complete non-rot external flooring systems for a variety of applications.

Made from 100% recycled plastic, it does not rot, split or crack and is suitable for damp/ wet areas including jetties, fishing platforms, boardwalks and roof terraces.

Water resistant subframe specifications

Type	Dimensions	Colour
Post	100 x 100 x 3000	Black
Joist/Bearer	125 x 50 x 3000	Black
Joist*	50 x 50 x 2400	Black

* Used for roof terraces or solid base only

Made from 100% recycled plastic, it does not rot, split or crack...



Joist Shoes

Suitable for use with any of Balconette's Decking products, joist shoes are ideal for use on hard surfaces. They are also widely used on roofs as they do not puncture the roof membrane; allow water to flow between joists and roof and create an air gap for 'breathability'. A further benefit of the joist shoes is that they reduce sound transfer.



Joist Spacing

For residential use, a joist spacing of 400mm is recommended and on heavy commercial, bridges, balconies, moorings, doorways and steps a 300mm joist spacing is recommended. (A minimum of 3 joists are required for any cut boards.)



Pedestals

Balconette's adjustable roof pedestals are ideal for decking on balconies. Pipework can be laid underneath while allowing room for breathability and preventing rot in the joists. Adjustable pedestals are available up to 210mm high.



Ring supports

Ring supports are designed for low height areas creating airflow and protecting the roof membrane. Water can flow off easily, preventing pooling.



Charred

Advantages and specification of Balconette's Composite Decking



The inspired decking solution

Unlike natural wood decking, Balconette's Composite Decking is durable and long-lasting due to its polyurethane and mineral blend. It is also protected from UV rays. Natural timber is extremely porous and hosts algae growth, whereas composite decking is virtually maintenance-free, non-porous, does not host algae and has self-cleaning properties. Because there is no algae growth, this reduces the risks of accidents and slipping.

For areas where food and drink is served, Balconette's decking is the ideal choice. Anything that is accidentally spilt can be easily wiped up leaving no stains or marks. Staining can be a problem with timber decking as stains are more difficult to remove from wood.

Advantages

- Virtually maintenance-free
- 25-year residential warranty
- Resistant to scratches and stains
- UV Stable
- Versatile
- Doesn't warp or expand like wood
- Durable and anti-abrasive
- Doesn't host algae growth
- Safer and cheaper alternative to wood

	UV stable hard wearing polymere	Size options				Colour options							Fixing type	Coverage inc 4mm gap	
		146 x 3200 x 16	176 x 3600 x 32	200 x 3200 x 32	50 x 2400 x 33	Coppered Oak	Smoked Oak	Golden Oak	Limed Oak	Jarrah	Driftwood	Vintage	Carbonised	Ghost Fixings stainless steel trimhead	Boards per M ² Installed
Enhanced Grain	•		•			•	•	•	•	•				•	1.54
Weathered	•			•							•	•		•	1.36
Charred	•		•										•	•	1.54
Embered	•			•									•	•	1.36
Square edging	•				•	•	•	•	•	•	•	•		•	n/a
Bullnosed edging	•				•	•	•	•	•	•	•	•		•	n/a
Fascia board	•	•				•	•	•	•	•	•	•		•	n/a

Case study: Balconette's balustrade and decking are perfect partners

Glass balustrading and composite decking from Balconette make perfect partners for gardens as demonstrated by this elegant example at Crowborough, near Tunbridge Wells, Kent.



Limed Oak

Summers spent outside await a delighted Deborah and Nigel Gooch after giving their original 14-year-old paved patio a complete 'low-maintenance' make-over.

The new decking, in a pale Limed Oak finish, is made from a unique polyurethane and mineral blend providing long-lasting durability with a slip-resistant surface and minimal maintenance. It is complemented with the Balcony 1 balustrading system using Balconette's proprietary Royal Chrome anodised finish handrail.

The couple also specified Balconette's BalcoNano® self-cleaning glass coating on the curved and straight panels which noticeably reduces the need for cleaning. The protective coating creates a smooth, water-repellent surface so dirt and other deposits cannot cling and are easily washed off by rain or wiping with a wet cloth.

"The end result is absolutely stunning, to say it's a transformation is an understatement," enthuses Deborah. "It really has transformed the whole garden and it all looks so much better and brighter. The smoothness and uniform colour of the decking makes the area look bigger, although it is still the same size."

"We also replaced old wooden decking by the pond which was a no-go area in the winter because it was so slippery with mould. It was literally a 'death-trap' from October to March, but now we can use it safely all year-round."



Limed oak

When planning their patio renovation, Deborah and Nigel, who have a young granddaughter, considered rope or railings to provide a barrier to the four-foot drop below. "No one had fallen off in 14 years, but a two-year-old might. We struggled to find a suitable balustrade as we didn't want to block the view," continues Deborah.

A visit to a local garden with a 'fantastic glass balustrade' inspired them to contact Balconette who put them in touch with Peter Leck and Simon Ritchie's Tunbridge Wells based installation company, one of Balconette's Approved Installers across the UK.

Deborah explains: "Until then, I didn't know about glass balustrading but realised that it was the solution we needed. Finding the glass was a real revelation, matching our requirement to keep the garden views. Then Simon's suggestion to also install Balconette's

Composite Decking was brilliant. The two products go together beautifully and have given us a lovely new outdoor space to enjoy.

"We also replaced old wooden decking by the pond which was a no-go area in the winter because it was so slippery with mould. It was literally a 'death-trap' from October to March but now we can use it safely all year-round."

Being able to offer both balustrading and decking has expanded the options for Balconette's Approved Partners like Peter and Simon. "Customers appreciate the convenience of being able to have the complete design-to-installation package from one company which also gives them peace of mind throughout the entire process," says Peter.

He adds: "Both products offer great versatility and work together so well to create a fabulous-looking solution like this one!"



"The end result is absolutely stunning; to say it's a transformation is an understatement," enthuses Deborah. "It really has transformed the whole garden and it all looks so much better and brighter. The smoothness and uniform colour of the decking makes the area look bigger, although it is still the same size."

Limed oak

Join Balconette's National Registered Partners Programme

We operate a growing Registered Partners Programme throughout the UK, stretching from Cornwall to North Scotland.

Our approach is to develop long-term partnerships with trade customers who sign up to our Registered Partners Programme. The comprehensive support package includes training, product discounts, referral of enquiries and dedicated literature to help close sales, as well as installation advice.

"We are always looking for professionals that we can collaborate with and recommend as potential local partners of our products to clients in their areas," says Effi Wolff, Balconette's Managing Director.

"Our expanding network has helped to open up new sales opportunities for window, door and home improvement companies as well as installers and builders involved in all types of fenestration, refurbishment and improvement projects."

Our Registered Partners can offer clients a full service, from initial site surveys, design and drawings through to final installation, ensuring complete customer satisfaction from start to finish.

One of the newest partners, Dan Smith, of DWL Windows in Sittingbourne, Kent, comments: "We were getting more and more demand for glass balustrading and balconies, so when Chris at Balconette mentioned the November seminar, we jumped at the chance to participate. Since then, we have quoted for a number of projects and we're expecting

interest and sales to grow further."

Impressed after seeing the quality and aesthetics of Balconette's products at Grand Designs Live, David Bromley became a Registered Partner and offers a full installation service in the North West.

"When we saw the stand, my thought was 'Wow!' and my operations director Robert Allen was blown away. We were gobsmacked by the amazing product range and decided we wanted to do this," says David.

"Balconette's support has been great and we have developed a close working partnership with the team. Enquiries are coming in providing new opportunities for us in the private residential sector," he continues.

"Balconette's products offer a wonderful combination of affordability and fantastic looking products to the homeowner. We are thrilled to be part of the Registered Partner network and are very hopeful and confident that great things will come from it," adds David.

For Aberdeenshire based joiner Simon Elms, becoming a Registered Partner has added sales and given his business a new dimension with mutual benefits. He signed up having been impressed with the Balconette glass and aluminium balustrading system he installed for a client.

"I've used a number of balustrading systems and the Balconette one is

certainly a good quality product that sells - and at a very competitive price. Decking

systems frequently need a secure barrier and adding the Balconette range has given me another 'string to my bow'," says Simon.

"It has opened up opportunities for more work; for example, architects are asking me to quote for installation projects having been referred to me through Balconette. In turn, I'm introducing more people to them so there are definitely reciprocal benefits," he adds.

For Kent based Peter Nelmes, who has been working with Balconette since 2005, being part of the programme has improved his business 100%. He adds: "Balconette refers leads to me and they're keeping me very busy. Having worked with balustrades and railings most of my life I can say for a fact that the Balconette glass balustrade is very well designed, you can tell that it has come from people who have worked on site and it goes together a treat."

Welding and fabrication business owner Alan Snowden, who joined in 2012 as a Registered Partner for the South West, is convinced of the benefits. He says: "I get quite a few leads from Balconette; they're a great team with really good products that



look sleek and are easy to install."

He adds: "The anodised aluminium handrail does not rust, so is perfectly suited to the coastal climate here. Clients also like the post-less system that keeps clear views. They all choose the self-cleaning glass coating too, as it enhances the products' low-maintenance."

Joining the programme in 2011 has helped to grow Peter Leck and Simon Ritchie's Tunbridge Wells-based construction company. They comment: "It's definitely added an extra element to our business and the products are easy to install. It's the best balustrading system available, in my opinion, which is why we find it easy to sell to our customers."

We hold one-day seminars at our offices for prospective partners on a monthly basis. In addition to a full introduction to the Partners Programme, the seminars cover product and sales training on the full Balconette range and include 'hands-on' demonstrations of how to install the unique balustrading systems. To learn more or book a space at a seminar either call our offices or email us at partners@balconette.co.uk.

Balconette continues to expand



“The general economic upturn and greater activity in the construction sector is having a positive impact on our business which continues to grow year-on-year.”

Balconette continues to go from strength-to-strength since moving to its UK headquarters at Blindley Heath in Lingfield on the Sussex and Surrey border in 2010. Since then, sustained investment in people, premises and products has continued to drive the company forward.

Located in a prominent position on the main A22 Eastbourne Road only a few miles from the M25 and M23, the site is easily accessible for visitors from across the UK and beyond. The premises comprise of warehousing and manufacturing areas together with a showroom and spacious offices for the technical, sales and administration functions.

In recent months, manufacturing output has risen by 50% and staffing

levels increased by 20% in response to demand across Balconette’s product portfolio from all market sectors. Growth has also been boosted with new products including an expanded Juliet balcony range and wood-free external decking.

“The general economic upturn and greater activity in the construction sector is having a positive impact on our business which continues to grow year-

on-year,” comments Effi Wolff, Balconette’s Managing Director.

“As a result, we are continuing to invest in our premises, personnel and machinery to maintain our position as one of the UK’s leading suppliers of glass balustrading and curved sliding patio doors,” he continues.

Effi states that their decision to move into larger premises during uncertain times ‘proved correct by

giving us the necessary space for expansion, both now and for the future, enabling us to maintain investment to keep ahead of the game and remain an influential player in the field.’

He adds: “With our investment plans in place, we are looking to the future with confidence servicing the market both locally and abroad.”

Balconette . . . passion for excellence

Balconette is one of the UK's leading specialist solution providers of innovative and aesthetically-stunning glass balustrades, Juliet balconies, curved glass, patio doors and composite decking.

Balconette's technically advanced and unique proprietary systems have been developed from many years of passion and experience to give spectacular, design-led results.

Curved and bespoke shapes can be accommodated through our extensive manufacturing expertise,

which includes our own aluminium and glass bending capability.

Balconette is specified by architects, contractors, developers, home improvers and self-builders alike.

Balconette's unique products allow the creation of exciting unusual



designs and shapes for all types of new build, refurbishment and renovation projects.

All Balconette's products are designed with low-maintenance in mind and they are the first to offer a unique self-cleaning glass coating across their entire range. Glass can be specified with their proprietary and double-sided BalcoNano® self-cleaning glass coating that reduces cleaning cycles.

From individual balcony projects to the largest commercial schemes, Balconette aims to deliver inspirational solutions that can truly transform buildings and outdoor spaces.

From individual balcony projects to the largest commercial schemes, Balconette aims to deliver inspirational solutions that can truly transform buildings and outdoor spaces.



T: 01342 410411

E: sales@balconette.co.uk

www.balconette.co.uk

Balconette, Unit 6 Systems House, Eastbourne Road
Blindley Heath, Surrey RH7 6JP

Balconette is a trading name of Balcony Systems Solutions Ltd.

